



Cisco Video Surveillance 5010/5011 Indoor Fixed HD IP Dome Camera User Guide

Americas Headquarters

Cisco Systems, Inc.
170 West Tasman Drive
San Jose, CA 95134-1706
USA
<http://www.cisco.com>
Tel: 408 526-4000
800 553-NETS (6387)
Fax: 408 527-0883

THE SPECIFICATIONS AND INFORMATION REGARDING THE PRODUCTS IN THIS MANUAL ARE SUBJECT TO CHANGE WITHOUT NOTICE. ALL STATEMENTS, INFORMATION, AND RECOMMENDATIONS IN THIS MANUAL ARE BELIEVED TO BE ACCURATE BUT ARE PRESENTED WITHOUT WARRANTY OF ANY KIND, EXPRESS OR IMPLIED. USERS MUST TAKE FULL RESPONSIBILITY FOR THEIR APPLICATION OF ANY PRODUCTS.

THE SOFTWARE LICENSE AND LIMITED WARRANTY FOR THE ACCOMPANYING PRODUCT ARE SET FORTH IN THE INFORMATION PACKET THAT SHIPPED WITH THE PRODUCT AND ARE INCORPORATED HEREIN BY THIS REFERENCE. IF YOU ARE UNABLE TO LOCATE THE SOFTWARE LICENSE OR LIMITED WARRANTY, CONTACT YOUR CISCO REPRESENTATIVE FOR A COPY.

The following information is for FCC compliance of Class A devices: This equipment has been tested and found to comply with the limits for a Class A digital device, pursuant to part 15 of the FCC rules. These limits are designed to provide reasonable protection against harmful interference when the equipment is operated in a commercial environment. This equipment generates, uses, and can radiate radio-frequency energy and, if not installed and used in accordance with the instruction manual, may cause harmful interference to radio communications. Operation of this equipment in a residential area is likely to cause harmful interference, in which case users will be required to correct the interference at their own expense.

The following information is for FCC compliance of Class B devices: This equipment has been tested and found to comply with the limits for a Class B digital device, pursuant to part 15 of the FCC rules. These limits are designed to provide reasonable protection against harmful interference in a residential installation. This equipment generates, uses and can radiate radio frequency energy and, if not installed and used in accordance with the instructions, may cause harmful interference to radio communications. However, there is no guarantee that interference will not occur in a particular installation. If the equipment causes interference to radio or television reception, which can be determined by turning the equipment off and on, users are encouraged to try to correct the interference by using one or more of the following measures:

- Reorient or relocate the receiving antenna.
- Increase the separation between the equipment and receiver.
- Connect the equipment into an outlet on a circuit different from that to which the receiver is connected.
- Consult the dealer or an experienced radio/TV technician for help.

Modifications to this product not authorized by Cisco could void the FCC approval and negate your authority to operate the product.

The Cisco implementation of TCP header compression is an adaptation of a program developed by the University of California, Berkeley (UCB) as part of UCB's public domain version of the UNIX operating system. All rights reserved. Copyright © 1981, Regents of the University of California.

NOTWITHSTANDING ANY OTHER WARRANTY HEREIN, ALL DOCUMENT FILES AND SOFTWARE OF THESE SUPPLIERS ARE PROVIDED "AS IS" WITH ALL FAULTS. CISCO AND THE ABOVE-NAMED SUPPLIERS DISCLAIM ALL WARRANTIES, EXPRESSED OR IMPLIED, INCLUDING, WITHOUT LIMITATION, THOSE OF MERCHANTABILITY, FITNESS FOR A PARTICULAR PURPOSE AND NONINFRINGEMENT OR ARISING FROM A COURSE OF DEALING, USAGE, OR TRADE PRACTICE.

IN NO EVENT SHALL CISCO OR ITS SUPPLIERS BE LIABLE FOR ANY INDIRECT, SPECIAL, CONSEQUENTIAL, OR INCIDENTAL DAMAGES, INCLUDING, WITHOUT LIMITATION, LOST PROFITS OR LOSS OR DAMAGE TO DATA ARISING OUT OF THE USE OR INABILITY TO USE THIS MANUAL, EVEN IF CISCO OR ITS SUPPLIERS HAVE BEEN ADVISED OF THE POSSIBILITY OF SUCH DAMAGES.

Cisco and the Cisco Logo are trademarks of Cisco Systems, Inc. and/or its affiliates in the U.S. and other countries. A listing of Cisco's trademarks can be found at www.cisco.com/go/trademarks. Third party trademarks mentioned are the property of their respective owners. The use of the word partner does not imply a partnership relationship between Cisco and any other company. (1005R)

Any Internet Protocol (IP) addresses and phone numbers used in this document are not intended to be actual addresses and phone numbers. Any examples, command display output, network topology diagrams, and other figures included in the document are shown for illustrative purposes only. Any use of actual IP addresses or phone numbers in illustrative content is unintentional and coincidental.

Cisco Video Surveillance 5010/5011 Indoor Fixed HD IP Dome Camera User Guide
© 2010, 2011 Cisco Systems, Inc. All rights reserved.



CONTENTS

Preface vii

CHAPTER 1

Introduction	1-1
Models	1-1
Getting Started	1-1
Parts List	1-2
Product Overview	1-2
Product Label	1-4

CHAPTER 2

Installation	2-1
In-Ceiling Installation	2-1
Surface Installation	2-4
Dome Liner and Lower Dome Installation	2-7
Service Cable	2-9
Wiring	2-10
Cat5 or Cat6 Cable	2-10
24 VAC Connector	2-11
Single Camera Wiring	2-11
Multiple Camera Wiring	2-12
Alarm and Relay Connector	2-12
Connecting a Relay Device	2-13
Connecting Alarms	2-13

CHAPTER 3

Operation	3-1
Camera Configuration Sequence	3-1
Minimum System Requirements	3-1
Accessing the IP Camera	3-2
Logging on to the Camera	3-2
Live Video Page	3-3
Live Video Page Icons	3-3
Selecting a Stream	3-4
Primary Stream and Secondary Stream	3-5
QuickView Stream	3-5

- Unicast **3-5**
- Taking a Snapshot **3-6**
- Displaying Video in the Multiscreen View **3-6**
- Settings Page **3-6**
 - Accessing the Camera Menus **3-7**
- System Tab **3-7**
 - Changing the Device Name **3-7**
 - Configuring the Time Settings **3-8**
 - Customizing the Appearance of the Text Overlay **3-8**
 - Generating a System Log **3-9**
 - Rebooting the Camera **3-9**
 - Restoring All Camera Defaults **3-9**
- Network Tab **3-9**
 - Changing the Hostname **3-10**
 - Turning On DHCP **3-10**
 - Turning Off DHCP **3-11**
- Imaging Tab **3-11**
 - Configuring the Orientation of the Scene **3-13**
 - Changing the Digital Processing Settings **3-14**
 - Selecting Auto Exposure Settings **3-15**
 - Selecting Manual Exposure Settings **3-17**
 - Day Night Settings **3-18**
 - Day Night Auto and Manual Modes **3-18**
 - Day Night Auto Mode **3-18**
 - Day Night Manual Mode **3-18**
 - Configuring Auto Focus Settings **3-19**
 - Configuring Manual Focus Settings **3-20**
 - Setting Tone Map Options **3-21**
 - Selecting Auto White Balance Settings **3-22**
 - Selecting Manual White Balance Settings **3-23**
 - Turning On Window Blanking **3-24**
 - Turing Off Window Blanking **3-24**
 - Deleting a Window Blanking Area **3-25**
- A/V Streams Tab **3-25**
 - Selecting a Video Preset Configuration **3-26**
 - Configuring a Custom Video Stream Configuration **3-27**
 - Compression Standards **3-28**
 - Available Camera Resolution **3-28**
 - Image Rate **3-28**

Bit Rate	3-28
Quality of Service for Differentiated Services Code Point	3-28
Rate Control	3-29
Profile	3-29
Advance Sharpening	3-30
Users and Groups Tab	3-30
Creating a New User	3-31
Editing a User	3-32
Deleting a User	3-32
Creating a New Group	3-33
Editing a Group	3-33
Deleting a Group	3-33
General Settings for Users and Groups	3-34
Setting the Camera to Node	3-34
Setting the Camera to Mixed	3-35
Events Tab	3-35
Sources	3-36
Creating an Alarm Event Source	3-36
Creating a System Event Source	3-37
Creating a Timer Event Source	3-37
Editing an Event Source	3-37
Deleting an Event Source	3-37
Handlers	3-38
Creating an Event Handler: Send Email	3-38
Creating an Event Handler: Write JPEG to SD Card	3-39
Creating an Event Handler: Upload JPEG to FTP Server	3-40
Creating an Event Handler: Open/Close Relay	3-40
Editing an Event Handler	3-41
Deleting an Event Handler	3-41
Example Handler Filter Setup	3-42
Help Menu	3-42
Log Off Menu	3-42



Preface

Obtaining Documentation and Submitting a Service Request

For information on obtaining documentation, submitting a service request, and gathering additional information, see the monthly *What's New in Cisco Product Documentation*, which also lists all new and revised Cisco technical documentation, at:

<http://www.cisco.com/en/US/docs/general/whatsnew/whatsnew.html>

Subscribe to the *What's New in Cisco Product Documentation* as a Really Simple Syndication (RSS) feed and set content to be delivered directly to your desktop using a reader application. The RSS feeds are a free service and Cisco currently supports RSS version 2.0.



CHAPTER 1

Introduction

The 5010/5011 cameras are fixed network dome cameras with a built-in Web-based viewer for live streaming to a standard Web browser (Microsoft Internet Explorer 8).

The cameras support standard H.264 and MJPEG compression formats and dual video streams that can be configured for a variety of resolutions, frame rates, and bit rates.

Each camera also includes a 2.8 - 8mm Varifocal Megapixel lens, a ready-to-install indoor enclosure, and a mechanical IR cut filter for increased low-light sensitivity. Additional lenses are available, and the cameras accept a wide range of megapixel varifocal CS-mount lenses.

The cameras also include built-in Power over Ethernet (PoE), which supplies power to the camera through the network. If PoE is not available, the camera is prewired for 24 VAC.

Models

CIVS-IPC-5010	Indoor fixed dome network camera, 2.1 megapixel, day/night, and a 2.8 ~ 8 mm varifocal megapixel lens. This camera has a <i>clear</i> dome.
CIVS-IPC-5011	Indoor fixed dome network camera, 2.1 megapixel, day/night, and a 2.8 ~ 8 mm varifocal megapixel lens. This camera has a <i>smoked</i> dome.

Getting Started

Before installing your network camera, thoroughly familiarize yourself with the information in this section of the manual.



Note

- Do not use a network hub when configuring the network settings for the camera.
 - To ensure secure access to the network camera, place the camera behind a firewall when it is connected to a network.
-

Parts List

Remove all of the contents from the shipping box.

Qty	Description
1	Back box with camera module
1	Surface mount
1	Lower dome (includes trim ring and bubble)
1	Dome liner
1	4-pin connector
1	2-pin connector
1	Quick Start Guide

Product Overview

Figure 1-1 Camera Connections and Features (Side View)

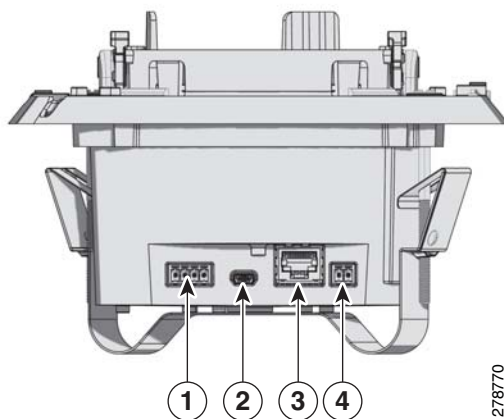

1	Relay and Alarm Connections: One relay that can be used to control an external circuit, and one alarm for physical input into the system.
2	Accessory Port: For use with compatible accessories.
3	RJ-45 Network Port: Connects the camera to the IP network. Also supplies power to the camera through the network using PoE. If PoE is not available, the camera is prewired for 24 VAC.
4	24 VAC Power Connections: Supports 24 VAC as the power source if PoE is not used.

Figure 1-2 Camera Connections and Features (Top View)

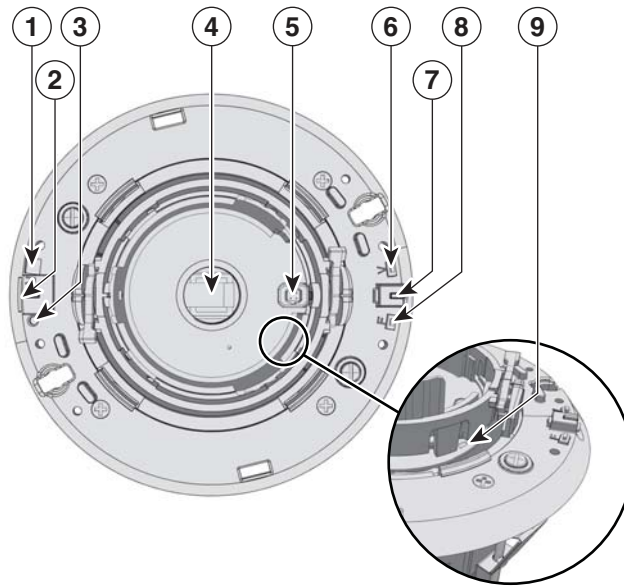

1	Reset Button: Reboots the camera or restores the camera's factory default settings. This button is recessed. Using a small tool, such as a paper clip, press and release the reset button once to reboot the camera. Press and hold the reset button for 10 seconds to restore the camera to the factory default settings.
2	Micro SD Card Slot: Saves a snapshot image to a micro SD card based on alarm activity.
3	Power LED: Glows solid green to indicate that the camera has power and flashes green during the boot cycle. The LED can be disabled through the user interface. If this LED glows red (solid or flashing), contact Cisco support for assistance.
4	Lens Mount: Fits a standard CS-mount lens. Use a megapixel lens with the 5010/5011 cameras. A standard definition lens installed on a megapixel camera will limit the resolution of the camera and create poor image quality.
5	Auto Iris Lens Connector: Controls the auto iris lens. Insert the 4-pin connector from the DC drive auto iris lens into this connector.
6	NTSC/PAL Button: Toggles the service connector between NTSC and PAL formats. The default setting is NTSC.
7	Service Port: Outputs analog video. Use this port at the installation site to set up the field of view and to focus the camera. When a service cable is connected to the camera, video to the IP stream is disabled.
8	Auto Back Focus Button: Sets the auto back focus mechanism. Press the button once to center the auto back focus mechanism and to fully open the iris. Press and hold the button for three seconds to start the auto back focus mechanism and focus the camera.
9	Ethernet Activity/Link LED: Flashes green to indicate that data is being transmitted or received by the camera. Glows solid amber to indicate that a live network connection is established and then turns off after one minute of operation.

Product Label

The product label lists the model number, date code, serial number, and Media Access Control (MAC) address. This information might be required for setup. The product label is located on the side of the back box.



CHAPTER 2

Installation

You can install the 5010/5011 network dome camera using one of the following methods:

- Installation in a suspended ceiling or a fixed ceiling/wall (refer to “[In-Ceiling Installation](#)” section on page 2-1).
- Mounting to the surface of a ceiling/ wall (refer to “[Surface Installation](#)” section on page 2-4).

In-Ceiling Installation



Warning

Remove the foam insert from the back box before installing the system. The foam is inserted to secure the tilt ring; preventing damage to the optical chassis during shipment.

Step 1

Prepare the mounting surface:

- a. Cut a 6-inch diameter hole in the ceiling.
- b. Pull all wiring through the hole and terminate all wires (if not already terminated).

Step 2

Install the lens on the back box:



Note

Megapixel lenses are designed and tested to deliver optimal image quality to megapixel cameras. A standard definition lens installed on a megapixel camera will limit the resolution of the camera and create poor image quality.

- a. Remove the cover from the lens mount.
- b. Screw the lens onto the lens mount. Be careful to prevent dust from entering the space between the lens and the imager. If necessary, use clean, compressed air to remove any foreign matter (refer to the instructions shipped with the lens). Make sure the lens does not touch the camera imager when installed.

- c. Connect the auto iris lens to the 4-pin connector located on the side of the camera. Pin connections for the iris drive connector are as follows:

Figure 2-1 Lens Pin Connections

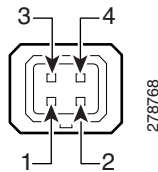

Pin	DC (AID) Auto Iris Lens
1	Control coil negative (-)
2	Control coil positive (+)
3	Drive coil positive (+)
4	Drive coil negative (-)

- Step 3** Connect the wiring to the side of the back box:
- Plug the network cable into the RJ-45 network port on the side of the camera. If the network has no PoE, connect a 24 VAC Class 2 power supply to the 24 VAC power connector. Refer to [“Wiring” section on page 2-10](#) for wiring connections.
 - Connect the necessary wiring for alarms and relays (refer to [“Wiring” section on page 2-10](#) more information.)
- Step 4** Install the back box by compressing the spring clips and pushing the back box through the hole. Tighten the machine screws completely to secure the back box to the ceiling.

Figure 2-2 In-Ceiling Installation

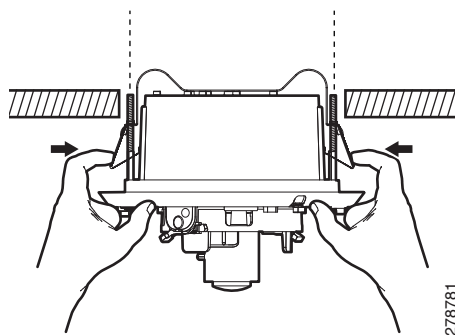

- Step 5** Apply power to the camera. The camera will complete a configuration sequence; the green LED flashes five times per second for approximately two minutes and then turns solid after the sequence is complete.



Note If the camera is not connected to a DHCP server and DHCP is enabled, the configuration sequence might take up to five minutes to complete.

- Step 6** Position the camera:
- View the camera image using the service jack or a Web browser.
 - Unlock the tab locks located on each side of the camera.
 - Manually rotate and tilt the camera module to position the camera. Do not over-rotate the module.
 - Lock the tab locks to secure the camera.

Figure 2-3 Positioning the Camera

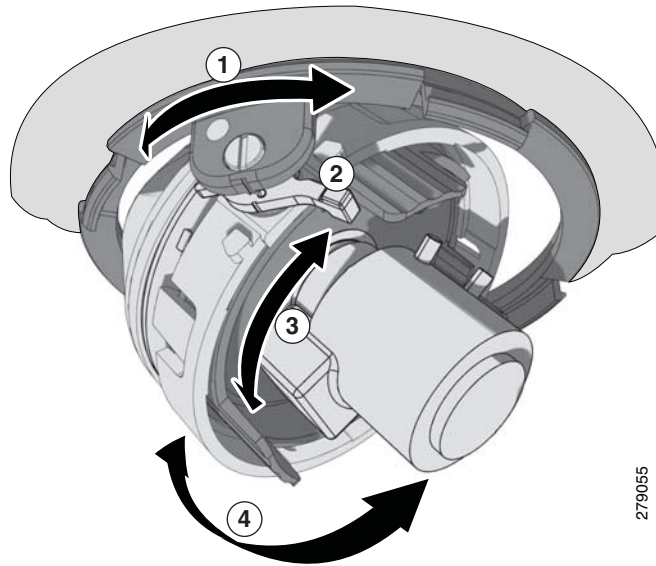

279055

1	Pan 368°	3	Rotate 355°
2	Tab lock	4	Tilt 180°

- Step 7** Focus the lens:
- View the camera image using the service jack or a Web browser.
 - Press the auto back focus button once to center the focus mechanism. The button is located on the rim of the back box.
 - Manually adjust the zoom and focus of the lens to the desired field of view (refer to the instructions shipped with the lens).
 - Press and hold the back focus button for three seconds to start the auto back focus mechanism.
- Step 8** Install the dome liner and lower dome (refer to [“Dome Liner and Lower Dome Installation”](#) section on page 2-7).

Surface Installation



Warning

Remove the foam insert from the back box before installing the system. The foam is inserted to secure the tilt ring; preventing damage to the optical chassis during shipment.

Step 1 Prepare the mounting surface:

- a. Using the surface mount ring as a template, drill holes for the mounting hardware. Prepare the ceiling as follows:
 - **Standard ceiling:** When mounting the dome camera to a standard ceiling, use either 6-32 toggle bolts (not supplied) or #8 x 3.50-inch self-tapping screws (not supplied).
 - **Concrete ceiling:** When mounting the dome camera to a concrete system, use 8-32 studs and nuts (not supplied).
- b. Drill a hole in the ceiling for wiring.
- c. Pull all wiring through the hole and terminate all wires (if not already terminated).
- d. Attach the surface mount ring to the mounting surface.

Step 2 Install the lens on the back box:



Note

Megapixel lenses are designed and tested to deliver optimal image quality to megapixel cameras. A standard definition lens installed on a megapixel camera will limit the resolution of the camera and create poor image quality.

- a. Remove the cover from the lens mount.
- b. Screw the lens onto the lens mount. Be careful to prevent dust from entering the space between the lens and the imager. If necessary, use clean, compressed air to remove any foreign matter (refer to the instructions shipped with the lens). Make sure the lens does not touch the camera imager when installed.
- c. Connect the auto iris lens to the 4-pin connector located on the side of the camera. Pin connections for the iris drive connector are as follows:

Figure 2-4 Lens Pin Connections

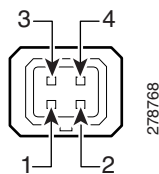

Pin	DC (AID) Auto Iris Lens
1	Control coil negative (-)
2	Control coil positive (+)
3	Drive coil positive (+)
4	Drive coil negative (-)

- Step 3** Connect the wiring to the side of the back box:
- Plug the network cable into the RJ-45 connector on the side of the camera. If the network has no PoE, connect a 24 VAC Class 2 power supply to the 24 VAC power connector. Refer to [“Wiring” section on page 2-10](#) for wiring connections.
 - Connect the necessary wiring for alarms and relays (refer to [“Wiring” section on page 2-10](#) for more information).
- Step 4** Install the back box in the surface mount ring by compressing the spring clips and pushing the back box through the hole. Tighten the machine screws completely to secure the back box to the ceiling.

Figure 2-5 Surface Back Box Installation

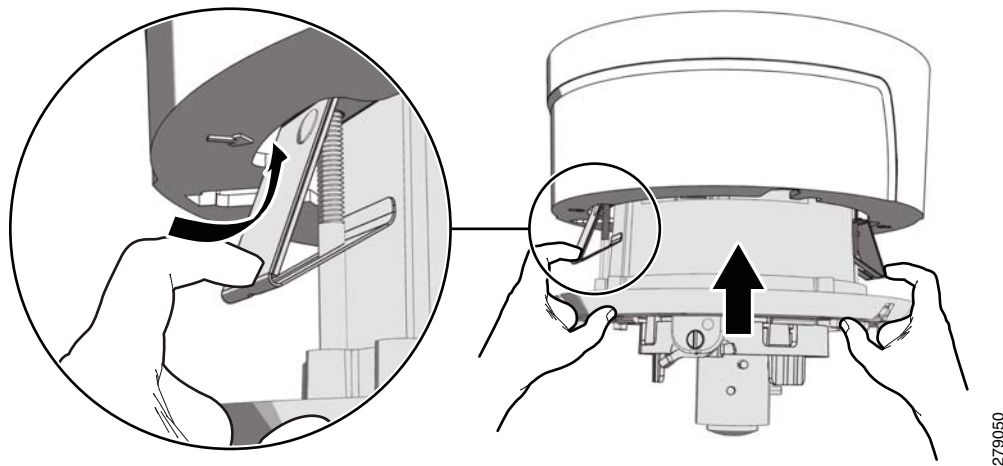

- Step 5** Apply power to the camera. The camera will complete a configuration sequence; the green LED flashes five times per second for approximately two minutes and then turns solid after the sequence is complete.



Note If the camera is not connected to a DHCP server and DHCP is enabled, the configuration sequence might take up to five minutes to complete.

- Step 6** Position the camera:
- View the camera image using the service jack or a Web browser.
 - Unlock the tab locks located on each side of the camera.
 - Manually rotate and tilt the camera module to position the camera. Do not over-rotate the module.
 - Lock the tab locks to secure the camera.

Figure 2-6 Positioning the Camera

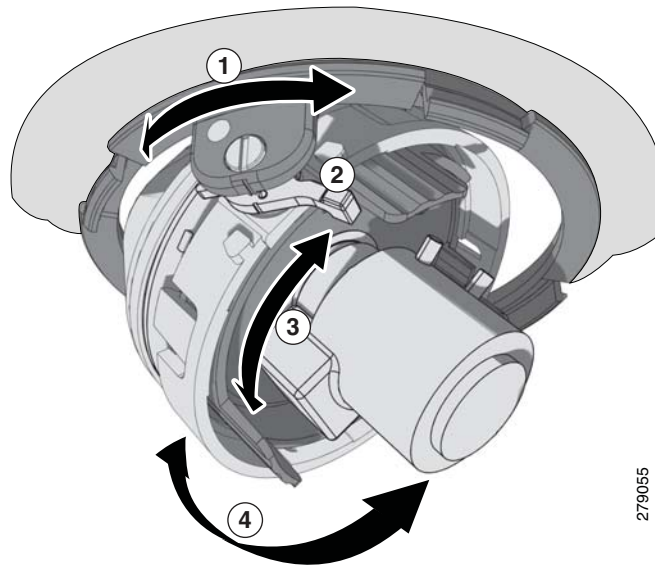

279055

1	Pan 368°	3	Rotate 355°
2	Tab lock	4	Tilt 160°

Step 7 Focus the lens:

- a. View the camera image using the service jack or a Web browser.
- b. Press the auto back focus button once to center the focus mechanism. The button is located on the rim of the back box.
- c. Manually adjust the zoom and focus of the lens to the desired field of view (refer to the instructions shipped with the lens).
- d. Press and hold the back focus button for three seconds to start the auto back focus mechanism.

Step 8 Install the dome liner and lower dome (refer to [“Dome Liner and Lower Dome Installation”](#) section on page 2-7).

Dome Liner and Lower Dome Installation

- Step 1** Align the magnets on the dome liner with the magnets located on the camera module.

Figure 2-7 *Installing the Dome Liner*

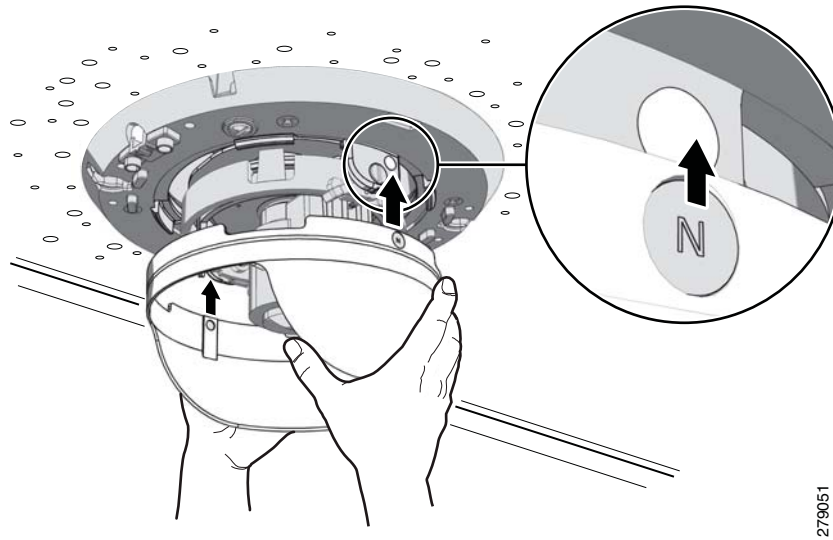

279051

- Step 2** Attach the leash of the lower dome to the back box.

Figure 2-8 *Attaching the Leash*

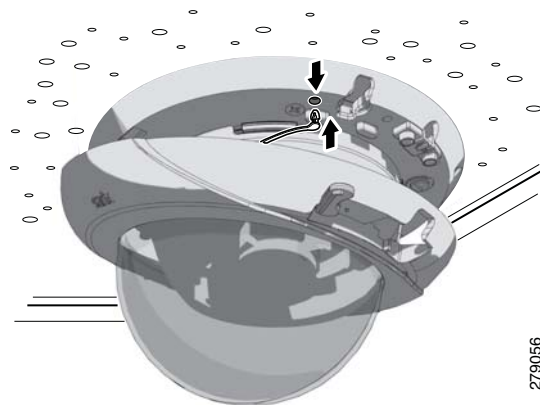

279056

- Step 3** Move the lower dome latches away from the bubble until you hear a click indicating the latches are open. Align the lower dome latches with the slots located on the camera module (refer to [Figure 2-9 on page 2-8](#)).



Warning

The lower dome latches must be in the open position. Never force the lower dome latches into the slots of the camera module.

Figure 2-9 *Aligning the Lower Dome with Camera*

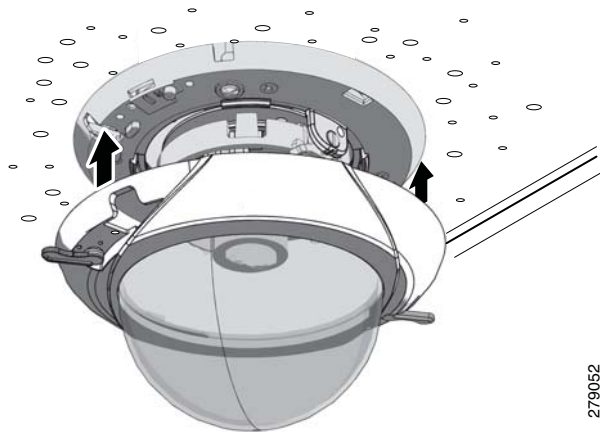

Step 4 Move the lower dome latches toward the bubble until you hear a click.

Figure 2-10 *Locking the Dome*

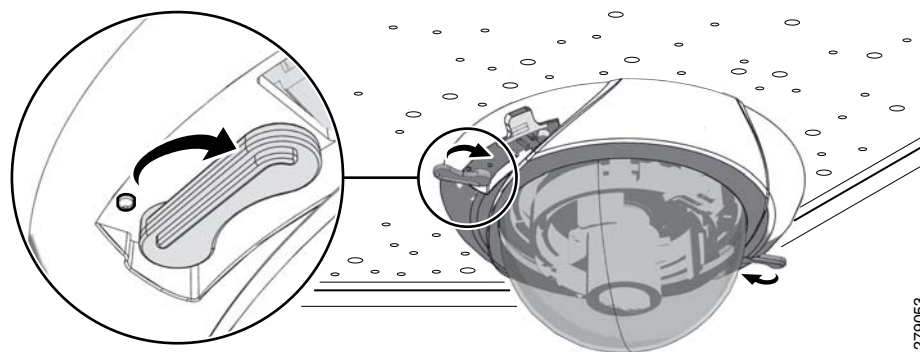

Step 5 Turn the top cover of the lower dome 90-degrees to conceal the camera latches, LED, and service jack.

Figure 2-11 *Positioning the Top Cover of the Lower Dome*

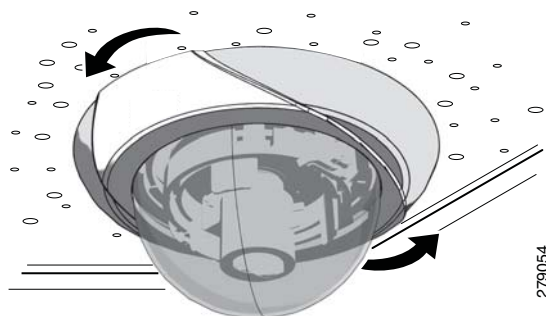

Service Cable

The dome camera includes a service port that outputs camera video. Use it at the installation site to set up the field of view and to focus the camera.

To assemble a service cable for the camera, you will need to purchase the following items from an electronics supply store:

Qty	Description
1	2.5 mm stereo plug (male)
1	CPM 88 miniature coaxial connector
1	RG174/U coaxial cable
1	1/8-inch shrink fit tubing, 1/2-inch long

To assemble the cable:

-
- Step 1** Attach the CPM 88 miniature coaxial connector to one end of the cable. Follow the directions supplied with the miniature coaxial connector.
- Step 2** Attach the 2.5 mm stereo plug to the other end of the coaxial cable (refer to [Figure 2-12 on page 2-10](#)):
- a. Remove the support sleeve from the plug.
 - b. Slip the shrink fit tubing and support sleeve over the end of the cable.
 - c. Prepare the cable:
 - d. Strip back the outer jacket 0.318 inch (8.06 mm) inch from the end of the cable.
 - e. Pull back the coaxial braid shield.
 - f. Strip back the insulating material 0.125 inch (3.18 mm) inch to expose the center conductor.
 - g. Solder the center connector of the cable to the center pin of the plug.
 - h. Pull the coaxial braid shield back through the crimp pin and solder it to the top of the crimp pin arm.
 - i. Crimp the end of the crimp pin around the cable.
 - j. Heat the shrink fit tubing around the center conductor and shoulder pin.
 - k. Reassemble the support sleeve and the plug.

Figure 2-12 Attaching the 2.5 mm Monaural Headphone Plug

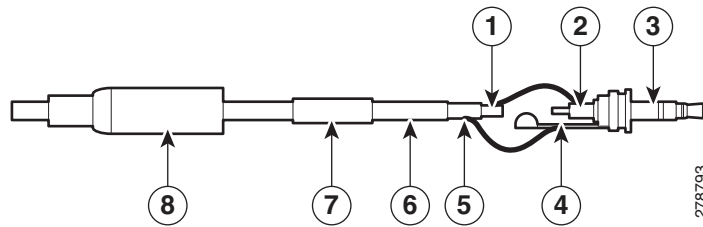

1	2.5 mm Stereo Plug	5	Shrink Fit Tubing
2	Plug Shoulder Pin	6	Coaxial Cable
3	Center Conductor	7	Coaxial Braid Shield
4	Support Sleeve	8	Crimp Pin Arm

Wiring

Cat5 or Cat6 Cable

Connect a Cat5 or Cat 6 cable to the RJ-45 network port. The 8-pin connector includes video and PoE for the camera. PoE (IEEE 802.3af Class 3) injects power over the same cabling that carries the network data, eliminating the need for a separate power supply. This simplifies the installation and operation of the camera without affecting network performance.



Note

- The camera will autosense and configure itself to use either a crossover cable or a straight cable.
- A CAT5 is sufficient for 100 MHz transmission. Use a CAT6 cable for both 100 and 1000 MHz transmission.

Refer to [Figure 2-13](#) for pin descriptions.

Figure 2-13 Cat5 or Cat6 Cable Pin Descriptions

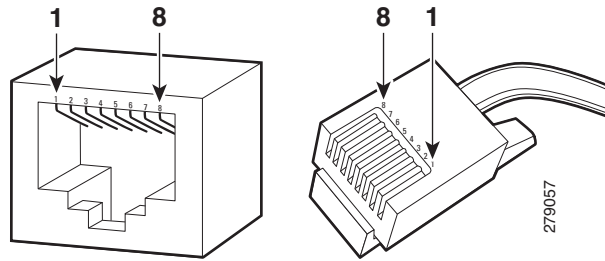

Pin	Function
1	TX+
2	TX-
3	RX+
4	PoE 1-2
5	PoE 1-2
6	RX-
7	PoE 3-4
8	PoE 3-4

24 VAC Connector

Single Camera Wiring

If PoE is not available:

Step 1 Connect the 24 VAC wires to the supplied 2-pin connector (refer to [Figure 2-14](#)).



Note Only use the 24 VAC wires if PoE is not available.

Step 2 Attach the mating connector to the green connector on the side of the camera.

Figure 2-14 24 VAC Connector

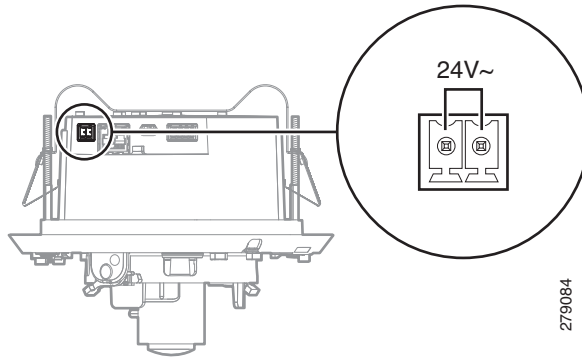

Multiple Camera Wiring

If you are operating the camera using 24 VAC and you are wiring more than one camera to the same transformer:

-
- Step 1** Connect one side of the transformer to pin 1 of the 2-position terminal block on all modules.
- Step 2** Connect the other side of the transformer to pin 2 of the terminal block on all modules.



Note Failure to connect all modules identically might introduce video noise for some installations

Alarm and Relay Connector

-
- Step 1** Connect the alarm and relay wires to the supplied 4-pin connector (refer to [Figure 2-15](#)).
- Step 2** Attach the mating connector to the green connector on the side of the camera.

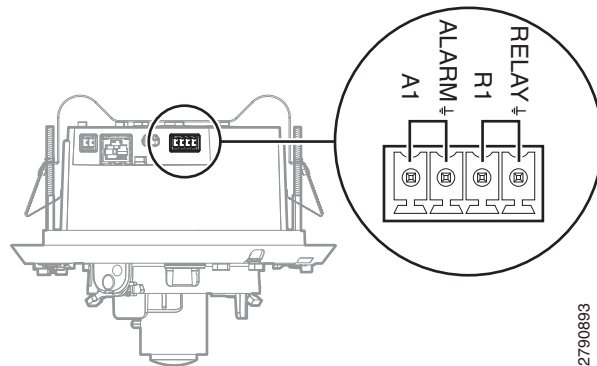
Figure 2-15 Alarm and Relay Connector

Connecting a Relay Device

The camera has an output for activating an external device. It supports both momentary and continuous relay operation.

You can operate the relay interactively during an active connection, or it can operate automatically to coincide with certain events. Typical applications include turning on lights or other electrical devices or activating a door, gate, or lock.



Warning

Do not exceed the maximum rating of 12 VDC, 0.15 A.

Figure 2-16 shows how to wire the relay with its power source to the camera.

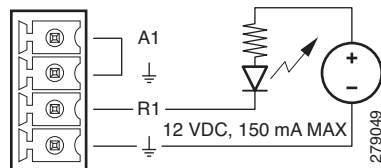
Figure 2-16 Relay Wiring

Connecting Alarms

The camera provides an alarm input for external signaling devices, such as door contacts or motion detectors. Both normally open and normally closed devices are supported.

Supervised Alarms

When an alarm is configured as a supervised alarm, the camera maintains a constant electrical current through the alarm circuit (3.3 VDC, 1 ohm). If the alarm circuit length changes, due to an electrical short or a bypass, the voltage fluctuates from its normal state and activates an alarm.

**Note**

Install the 1-kohm resistor as close to the switch as possible.

Figure 2-17 illustrates the alarm and no alarm conditions of a supervised alarm input. Whether the alarm is normally closed or normally open, neither a cut nor a bypass can defeat these alarms.

Figure 2-17 Supervised Alarm Conditions

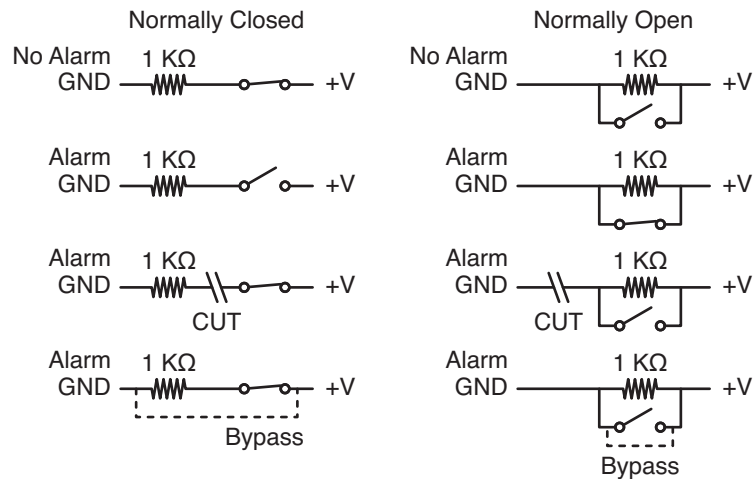
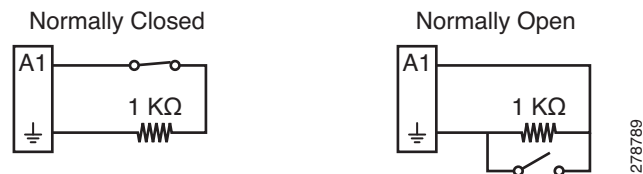

Figure 2-18 illustrates the wiring configuration for supervised alarm inputs.

Figure 2-18 Supervised Alarm Input Wiring



Unsupervised Alarms

When an alarm is configured as an unsupervised alarm, the camera only activates an alarm when the normal alarm state (open or closed) changes.

Figure 2-19 on page 2-15 illustrates the alarm and no alarm conditions of an unsupervised alarm input.

Figure 2-19 Unsupervised Alarm Conditions

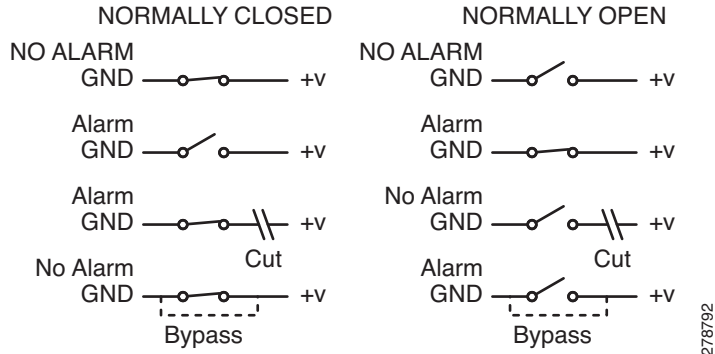

Figure 2-20 illustrates the wiring configuration for unsupervised alarm inputs.

Figure 2-20 Normally Closed and Normally Open Unsupervised Alarm Input Wiring



Note

A normally closed alarm input can be defeated with a bypass; a normally open input can be defeated with a cut.

Alarm Connections

Figure 2-21 shows how to wire the camera to an alarm.

Figure 2-21 Alarm Connections

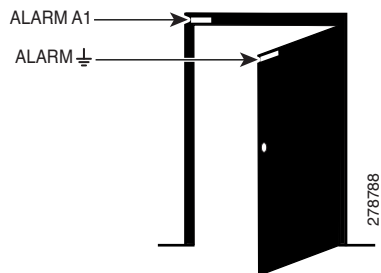



CHAPTER 3

Operation

Camera Configuration Sequence

Once the camera is installed and power is applied, the camera will start a configuration sequence: the green LED flashes five times per second for approximately two minutes and then glows solid green, indicating that the boot cycle is complete and the camera is on line.



Note

If the camera is not connected to a Dynamic Host Configuration Protocol (DHCP) server and DHCP is enabled, the configuration sequence might take up to five minutes to complete.

Refer to the following topics for more information:

- [Network Tab, page 3-9](#)
- [Turning On DHCP, page 3-10](#)
- [Turning Off DHCP, page 3-11](#)

Minimum System Requirements

Network and processor bandwidth limitations might cause the video stream to pause or appear pixilated when an increased number of Web interface users connect to the camera. Decrease the images per second (ips), resolution, compression, or bit rate settings of the Web interface video streams to compensate for network/processor limitations.

The following minimum system requirements are needed to use a Web browser with the IP camera:

- **Processor:** Intel® Core™ 2 Duo microprocessor, 2.6 GHz
- **Operating system:** Microsoft® Windows® XP
- **Memory:** 2 GB RAM
- **Network interface card:** 100 megabits (or greater)
- **Monitor:** Minimum of 1024 x 768 resolution, 16- or 32-bit pixel color resolution
- **Web browser:** Internet Explorer® 8.0
- **Media Player:** QuickTime 7.6.5 for Windows XP



Note This product is not compatible with QuickTime version 7.6.4 for Windows XP, Windows Vista. If you have this version installed on your PC, upgrade to QuickTime version 7.6.5.

Refer to the following sections for more information:

- [Compression Standards, page 3-28](#)
- [Available Camera Resolution, page 3-28](#)
- [Image Rate, page 3-28](#)
- [Bit Rate, page 3-28](#)

Accessing the IP Camera

The first time you access the camera, the live video page appears. By default, you are viewing the video as a public user and only have access to the single stream live view.

If, for security purposes, users should not be allowed to view video without first logging on to the camera, change the permissions for public users.

Logging on to the Camera

Step 1 Open the Web browser.

Step 2 Type the camera's IP address in the browser address bar.



Note If the camera is not connected to a DHCP server but DHCP is set to On, the default IP address 192.168.0.20 on subnet mask 255.255.255.0 is automatically assigned to the camera. After the first camera is connected and assigned the default IP address, the system will automatically look for other cameras on the auto IP address system and assign IP addresses in sequential order as required. For example if three cameras are connected to a network without a DHCP server, the first camera will be assigned address 192.168.0.20, the second camera will be assigned address 192.168.0.21, and the third camera will be assigned address 192.168.0.22. Contact your network administrator to avoid network conflicts before setting/changing the camera's IP address. See the [“Network Tab” section on page 3-9](#) for more information.

Step 3 Click the Login button in the navigation bar; a dialog box appears.

Step 4 Enter your user ID and password.



Note If you are logging on to the camera as the administrator for the first time, the default User ID and Password are **admin** (all lowercase). For security purposes, be sure to change the password after you log on for the first time.

Step 5 Click Log In.

Refer to the following section for more information:

- [Editing a User, page 3-32](#)

Live Video Page

The live video page allows you to manage the way you view live video and capture images. You can also view live video from this page and access menus on the navigation bar (based on user permissions).

Figure 3-1 *Live Video Page*

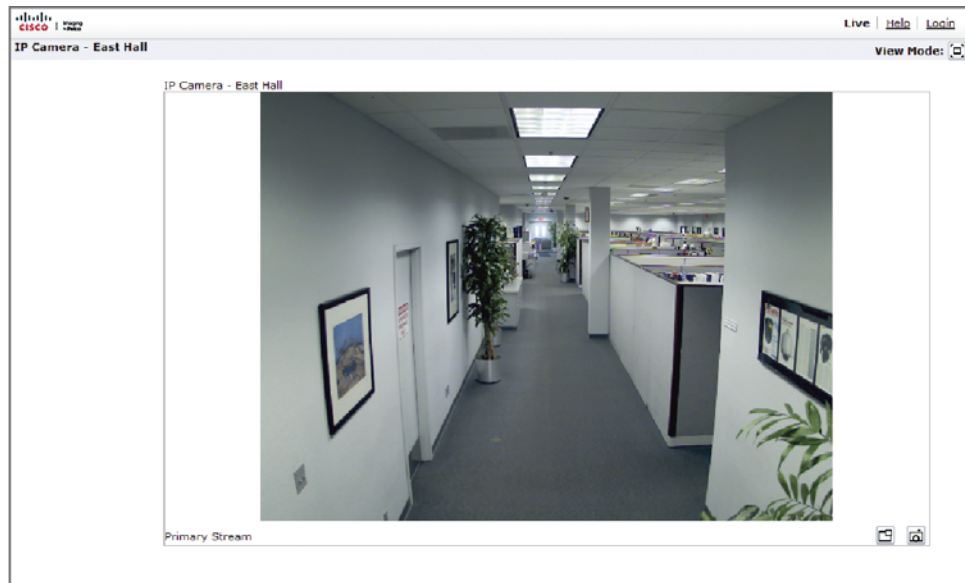











Refer to the following sections for more information:

- [Live Video Page Icons, page 3-3](#)
- [Selecting a Stream, page 3-4](#)
- [Taking a Snapshot, page 3-6](#)
- [Displaying Video in the Multiscreen View, page 3-6](#)

Live Video Page Icons

Viewable icons are based on user permissions.

	<p>Show Device List: Displays a list of viewable cameras connected to the same virtual local area network (VLAN) as the camera to which you are logged on.</p> <p>Note Used only in 2x2 mode to list other devices.</p>
	<p>Disable Viewer: Closes the live view window.</p> <p>Note Used only in 2x2 mode to list other devices.</p>

	1 x 1 Mode: Displays a single video pane.
	2 x 2 Mode: Displays 4 video panes in rows of two.
	3 x 3 Mode (full-screen mode only): Displays 9 video panes in rows of three.
	4 x 4 Mode (full-screen mode only): Displays 16 video panes in rows of four.
	Select Stream: Selects the viewable video stream that is displayed in live view (primary or secondary).
	Maximize Viewing Area: Scales the image to the full size of the browser. To resize the video pane to normal view, click the Show Toolbar button in the upper-right corner of the window.
	Show Toolbar: Returns the window to normal view. This option is only available after the window has been set to maximize the viewing area.
	Open Stream in New Window: Opens the video in a scalable, independent window. Opening the video in a separate window allows you to view the video while other applications are running. This window can be minimized, maximized, or closed using the title bar buttons of the active window. The window can also be resized by dragging the lower-right corner of the window.
	Take a Snapshot: Captures the image displayed in the video pane and then saves it as a JPEG file.

Selecting a Stream

Step 1 Click the Select Stream button.

Step 2 Select one of the following stream options from the Select Stream page:

- **Primary Stream:** To select this stream, click the button next to Primary Stream.
- **Secondary Stream:** To select this stream, click the button next to Secondary Stream.
- **QuickView Stream:** To select this stream, click the button next to QuickView Stream.



Note If the secondary stream has not been configured, only Primary Stream and QuickView Stream are available.

Step 3 Select one of the following options to adjust the stream settings:

- **H.264 compression:** Select the video transmission type from the Transmission drop-down menu.
- **JPEG compression:** Select the image rate for the stream from the Image Rate drop-down menu. The available settings for the primary and secondary streams depend on the Image Rate setting. The QuickView Stream has only two image rate settings: 2 ips and 1 ips.

Step 4 Click the View button to save the stream settings.

Refer to the following sections for more information:

- [Primary Stream and Secondary Stream, page 3-5](#)
- [QuickView Stream, page 3-5](#)
- [Unicast, page 3-5](#)
- [Compression Standards, page 3-28](#)
- [Image Rate, page 3-28](#)

Primary Stream and Secondary Stream

The Primary Stream and Secondary Stream are video streams that include compression, resolution, image rate, and bit rate settings. The streams can be set up using a video preset setting, or they can be customized using the video configuration settings.

A video preset is a pre-defined video configuration that offers a good balance between video performance and bandwidth usage. For easy stream configuration, see the [“Selecting a Video Preset Configuration” section on page 3-26](#).

To customize the Primary Stream or Secondary Stream use the Video Configuration page located in the drop-down menu of the A/V Streams Tab. See the [“Configuring a Custom Video Stream Configuration” section on page 3-27](#). Configurable settings include the stream name, compression standard, resolution setting, image rate, and bit rate. The default names for the streams are Primary Stream and Secondary Stream; however, if these stream names have been changed, the new names will replace the default names (Primary Stream and Secondary Stream) on the Select Stream page.

QuickView Stream

The QuickView Stream is a predefined JPEG video stream with VGA resolution. This low resolution, low frame rate stream is displayed when the Imaging Tab settings are configured. This allows users to view changes to exposure, white balance, and tone map settings as they are configured and before the settings are saved.

The QuickView Stream is also ideal for users who are connected to a network with processor bandwidth limitations that might cause a high resolution, high frame rate video stream to pause or appear pixilated.

The aspect ratio of the QuickView Stream mirrors that of the Primary Stream. The only stream setting that is selectable is the framerate: 2 ips or 1 ips.

Unicast

A unicast transmission sends a separate video stream to each user that is requesting data. Although multiple users might request the same data from the camera at the same time, duplicate video streams are transmitted to each user. Every unicast user that connects to the camera consumes additional processing power, which limits the number of simultaneous users who can access the camera.

The camera supports a maximum of 20 simultaneous users.

Taking a Snapshot

-
- Step 1** Click the “Take a Snapshot” button.
- Step 2** The File Download dialog box opens, and the following message appears: “Do you want to open or save this file?”
- Step 3** Select one of the following options:
- **Open:** Your computer’s photo editing program opens and displays the screen image. This function is available only when using Microsoft® Internet Explorer® 7.0 (or later) or Mozilla® Firefox® 3.0 (or later).
 - **Save:** The image is saved as a JPEG file on your computer.
 - **Cancel:** The captured image is not saved or displayed and the dialog box closes.



Note If you are using MJPEG, the captured image will be the size of the largest MJPEG stream. If you are using H.264, the image is captured using the QuickView Stream, which is approximately VGA resolution.

Displaying Video in the Multiscreen View

Cameras connected to the same virtual local area network (VLAN) as the camera to which you are logged on can be displayed in a multiscreen view. Use the 4-camera, 9-camera, or 16-camera view mode buttons to display video from multiple cameras simultaneously.

The camera you are logged on to is the default display for the upper-left video pane in the multiscreen view. The device name for this camera is displayed in the gray area near the top of all pages.

To select video to display in the individual multiscreen panes:

-
- Step 1** Click the desired View Mode display button.
- Step 2** Click the Show Device List button above the selected video pane. A list of cameras connected to the same VLAN as the camera to which you are logged on appears in the video pane.
- Step 3** Click the name of the camera you want to view. The live video of the selected camera appears in the video pane.
- Step 4** Repeat steps 1 through 3 for the remaining video panes.
-

Settings Page

Depending on user permissions, the Settings page allows you to manage camera system settings, set up users and groups, and control the camera.



Note The Settings menu might not be available if the user does not have permission to access this feature.

Accessing the Camera Menus

- Step 1** Log on to the camera.
- Step 2** Click the Settings link in the navigation bar located in the upper-right corner of the page; a list of menu tabs appears.
- Step 3** Place the mouse pointer over a tab to display a list of submenus.
-

Refer to the following sections for more information:

- [System Tab, page 3-7](#)
- [Network Tab, page 3-9](#)
- [Turning On Window Blanking, page 3-24](#)
- [Events Tab, page 3-35](#)

System Tab

Use the System tab to change the device name, configure the time settings, set up the text overlay for the live view, and display system information. You can also use the System tab to generate a system log, reboot the camera, or to restore the camera's factory default settings.

General Settings

The General Settings page includes programmable fields for the device name, time server, and text overlay settings. The device name is the user-friendly description of the camera displayed in the gray area near the top of screen. The time server is an external server that uses Network Time Protocol (NTP) to synchronize the camera date and time settings. The text overlay settings allow you to customize the appearance of the Web browser by displaying the device name and the date and time at the top or bottom of the live view.

You can also use the General Settings page to turn the camera's power LED on or off and to configure the Simple Mail Transfer Protocol (SMTP) server to send an email notification when an event handler is activated.

**Note**

Consult your network administrator for information on configuring email notification on your local network.

Information Settings

The System Information page fields are read-only and include the firmware version, hardware version, model number, and serial number of the system.

Changing the Device Name

- Step 1** Click the System tab.

- Step 2** Click the Device Name box and highlight the text.
 - Step 3** Type a user-friendly name into the Device Name box (2 to 64 characters). A user-friendly name makes it easier to recognize the device on the network. Examples of user-friendly names are Front Door, Lobby, or Parking Lot.
 - Step 4** Click Save to save the new device name, or click Reset to restore to the previously saved device name.
-

Configuring the Time Settings

If the camera is connected to a Dynamic Host Configuration Protocol (DHCP) network that has time server properties configured, the camera will synchronize automatically with the time server. If the DHCP network's time server properties are not configured or the network does not have a time server, you need to configure the DHCP settings manually.

Click the System tab.

- Step 1** Select General from the drop-down menu.
- Step 2** Type the IP address of the time server in the Time Server field. The time server is an external server that uses Network Time Protocol (NTP) to synchronize the camera date and time settings.
- Step 3** Select the Time Zone option. Select the continent and the region that are closest to the camera's location from the Time Zone drop down menus.



Note If your location observes a form of daylight saving time, the system will automatically change the time on the associated dates.

- Step 4** Set the Overlay setting. Select On to overlay the date and time on the video stream, or select Off to turn off this setting.
 - Step 5** Click the Save button to save the settings, or click the Reset button to clear all of the information you entered without saving it.
-

Customizing the Appearance of the Text Overlay

- Step 1** Click the System tab.
- Step 2** Select General from the drop-down menu.
- Step 3** Set the Text Overlay settings:
 - **Date/Time Overlay:** Select Show to display the date and time in the live view overlay. The default setting is Hide.
 - **Camera Name Overlay:** Select Show to display the device name in the live view overlay. The default setting is Hide.
- Step 4** Select the display position for the overlay from the Position drop-down menu. Selections include Top Right, Top Center, Top Left, Bottom Right, Bottom Center, and Bottom Left.

- Step 5** Click the Save button to save the settings, or click the Reset button to clear all of the information you entered without saving it.
-

Generating a System Log

- Step 1** Click the System tab.
- Step 2** Click the Generate System Log button to create a system log that can be used by technical support.
-

Rebooting the Camera

- Step 1** Click the System tab.
- Step 2** Click the Reboot Camera button to restart the camera. Rebooting the camera does not change the configured camera settings.
-

Restoring All Camera Defaults

This process cannot be undone; all user and custom settings will be lost.

- Step 1** Click the System tab.
- Step 2** Click the Restore All Camera Defaults button to restore the camera's factory default settings.



Note If the camera is not connected to a Dynamic Host Configuration Protocol (DHCP) network, the IP address settings for the camera will be lost and the server will not recognize the camera. DHCP On is the default setting for the camera IP address.

Refer to the following sections for more information:

- [Turning Off DHCP, page 3-11](#)

Network Tab

Use the Network tab to change the camera's general network settings.

General Network Settings

The General Network page includes programmable and read-only fields for network communication settings. Available settings include the Hardware Address, Hostname, IP Address, Subnet Mask, Gateway, and DNS Servers.

You can also enable or disable the Dynamic Host Configuration Protocol (DHCP) server from the General Network page. DHCP automatically assigns an IP address to the device if there is a DHCP server on the network. If DHCP is set to On, the IP address, subnet mask, gateway, and DNS server settings are read-only text. If DHCP is set to Off, these settings must be manually changed. The default camera setting for DHCP is On.

Refer to the following sections for more information:

- [Changing the Hostname, page 3-10](#)
- [Turning On DHCP, page 3-10](#)
- [Turning Off DHCP, page 3-11](#)

Changing the Hostname

- Step 1** Place your mouse pointer over the Network tab.
 - Step 2** Select General from the drop-down menu.
 - Step 3** Click in the Hostname box and highlight the text.
 - Step 4** Type a user-friendly name into the Hostname box (1 to 21 characters) using any combination of alphanumeric characters. A user-friendly name makes it easier to recognize the device on the network.
 - Step 5** Click the Save button to save the settings, or click the Reset button to clear all of the information you entered without saving it.
-

Turning On DHCP

The default Dynamic Host Configuration Protocol (DHCP) setting for the camera is DHCP On. If the DHCP option is set to Off, complete the following steps to reset it to On.

- Step 1** Place your mouse pointer over the Network tab.
- Step 2** Select General from the drop-down menu.
- Step 3** Select the On option for DHCP.
- Step 4** Click the Save button to save the settings, or click the Reset button to clear all of the information you entered without saving it.

**Note**

If the camera is not connected to a DHCP server but DHCP is set to On, the default IP address 192.168.0.20 on subnet mask 255.255.255.0 is automatically assigned to the camera. After the first camera is connected and assigned the default IP address, the system will automatically look for other cameras on the auto IP address system and assign IP addresses in sequential order as required. For example if three cameras are connected to a network without a DHCP server, the first camera will be assigned address 192.168.0.20, the second camera will be assigned address 192.168.0.21, and the third camera will be assigned address 192.168.0.22. Contact your network administrator to avoid network conflicts before setting/changing the camera's IP address.

Turning Off DHCP

**Warning**

Contact your network administrator to avoid any network conflicts before setting or changing the IP address of the device.

- Step 1** Place your mouse pointer over the Network tab.
- Step 2** Select General from the drop-down menu.
- Step 3** Select the Off option for the Dynamic Host Configuration Protocol (DHCP).
- Step 4** Change the following network settings as required:
 - **IP Address:** The address of the camera connected to the network.
 - **Subnet Mask:** The address that determines the IP network that the camera is connected to (relative to its address).
 - **Gateway:** The router that accesses other networks.
 - **DNS Servers:** The addresses of the dedicated servers that translate the names for Web sites and hostnames into numeric IP addresses.
- Step 5** Click the Save button to save the settings, or click the Reset button to clear all of the information you entered without saving it.

Imaging Tab

Use the Imaging tab to change the camera's general image settings, adjust the camera exposure, program the focus mechanism, adjust the tone map settings to increase scene detail, tune the white balance settings for scenes with fluctuating lighting conditions, or define window blanking privacy areas.

General Imaging Settings

General imaging settings include adjustments for camera orientation and digital processing. The Orientation settings reconfigure the image 180 degrees horizontally and 180 degrees vertically. Use these settings when installing the camera in an inverted position. If the orientation is not adjusted, the image will display upside down and mirrored.

Digital processing settings can be set to Auto or Manual to adjust the camera's sharpness, saturation, and contrast. When set to Auto, the camera continually delivers the best possible image by automatically adjusting the digital processing settings based on the scene. Auto is the default setting. Manual digital processing is recommended only for indoor applications that have a single, unchanging primary light source.

Exposure Settings

Exposure is the amount of light detected by the camera sensor. A scene with correct exposure settings has adequate detail and contrast between white and dark values. An image with too little or too much exposure eliminates detail in the scene. The camera features Auto and Manual exposure settings. Auto exposure automatically sets the amount of light detected by the camera sensor based on settings for light control, exposure compensation, and the day and night exposure times. Manual exposure sets the amount of light detected by the camera sensor based on a user-defined setting. Manual exposure is recommended only for indoor applications that have a single, unchanging primary light source. Auto is the default setting.

Focus Settings

Focus sets the back focus to the center focal point of the scene. The camera can be configured to back focus automatically or manually. Auto focus automatically back focuses the camera on the subject in the center of the scene. Manual focus turns off the auto focus mechanism and locks the camera at a user-specified position. The manual focus setting is recommended only for indoor applications that have a single, unchanging primary light source. The Focus page also includes Full Range Auto-Focus, Quick Auto-Focus, and a Factory Defaults.

Tone Map Settings

Tone map balances the brightest and darkest sections of a scene to produce an image with more balanced lighting and more detail. This is accomplished, in part, when the device maps the 10-bit input sensor data (0 to 1023 bits) into 8-bit output RGB values (0 to 255 bits).

White Balance Settings

White balance settings define how the camera processes video images to render true colors in a scene. White balance is especially effective in scenes with changing lighting conditions or in scenes with more than one type of light source. For example, scenes that benefit from white balance correction are outdoor scenes, indoor scenes that include a window or door that opens to the outdoors, or indoor scenes that include both incandescent and fluorescent lighting.

Window Blanking Settings

Window blanking is used to conceal user-defined privacy areas. A blanked area appears on the screen as a solid gray window. The camera can handle up to four blanked windows as long as the total blanked area does not exceed 50 percent of the field of view.

Refer to the following sections for more information:

- [Configuring the Orientation of the Scene, page 3-13](#)
- [Changing the Digital Processing Settings, page 3-14](#)
- [Selecting Auto Exposure Settings, page 3-15](#)
- [Selecting Manual Exposure Settings, page 3-17](#)
- [Day Night Settings, page 3-18](#)

- [Configuring Auto Focus Settings, page 3-19](#)
- [Configuring Manual Focus Settings, page 3-20](#)
- [Setting Tone Map Options, page 3-21](#)
- [Selecting Auto White Balance Settings, page 3-22](#)
- [Selecting Manual White Balance Settings, page 3-23](#)
- [Turning On Window Blanking, page 3-24](#)
- [Turning Off Window Blanking, page 3-24](#)
- [Deleting a Window Blanking Area, page 3-25](#)

Configuring the Orientation of the Scene

Figure 3-2 Orientation Page

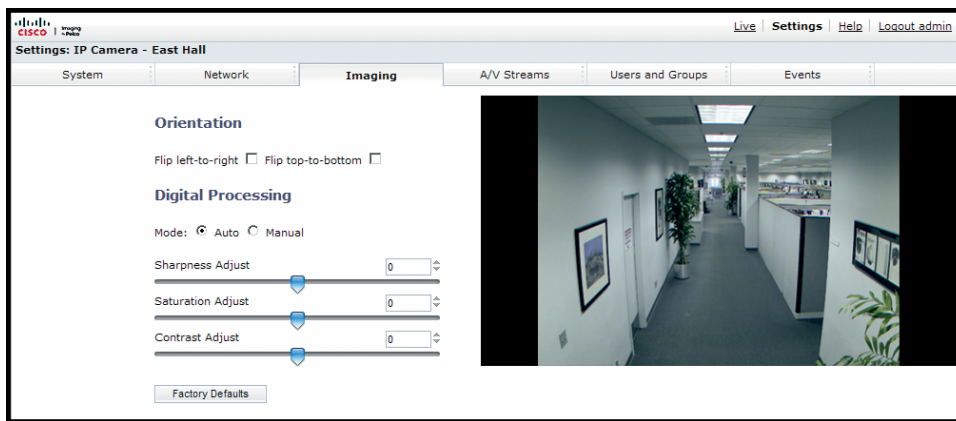

-
- Step 1** Place your mouse pointer over the Imaging tab.
- Step 2** Select General from the drop-down menu.
- Step 3** Select one of the following options:
- Click the “Flip left-to-right” box to rotate the camera image 180 degrees horizontally.
 - Click the “Flip top-to-bottom” box to rotate the camera image 180 degrees vertically.
-

Changing the Digital Processing Settings

Figure 3-3 Digital Processing Page

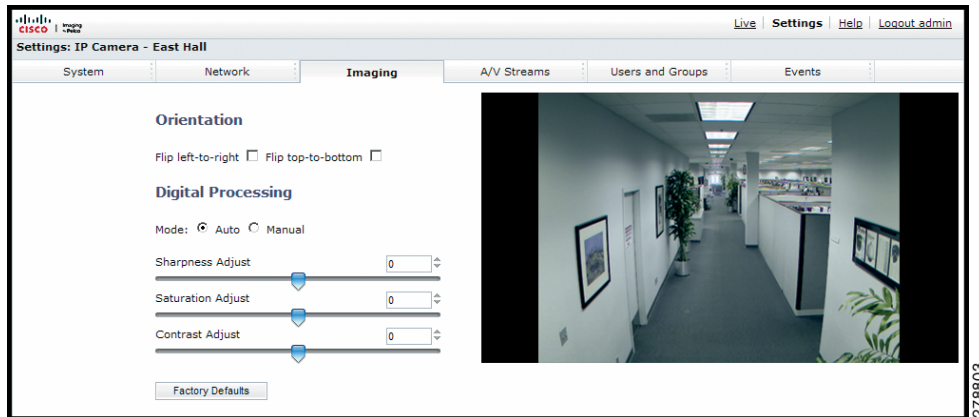

-
- Step 1** Place your mouse pointer over the Imaging tab.
- Step 2** Select General from the drop-down menu.
- Step 3** Select the mode: Manual or Auto. Auto is the default.
- Step 4** Move the slider to the left or right to change the following settings:
- **Sharpness Adjust/Sharpness:** Controls the clarity of detail in a scene. Move the slider to the right to increase the sharpness; move the slider to the left to decrease the sharpness. Increasing the sharpness also increases the image noise. The auto range of adjustment is –100 to 100; the auto default setting is 0 (zero). The manual range of adjustment is 0 to 100; the manual default setting is 50.
 - **Saturation Adjust/Saturation:** Controls how intense or vivid the colors are in a scene. Move the slider to the right to increase the saturation level; move the slider to the left to decrease the saturation level. The auto range of adjustment is –100 to 100; the auto default setting is 0 (zero). The manual range of adjustment is 0 to 100; the manual default setting is 50.
 - **Contrast Adjust/Contrast:** Controls gradations between the darkest and lightest portions of the scene. Move the slider to the right to increase the contrast; move the slider to the left to decrease the contrast. The auto range of adjustment is –100 to 100; the auto default setting is 0 (zero). The manual range of adjustment is 0 to 100; the manual default setting is 50.
-

Selecting Auto Exposure Settings

Figure 3-4 Auto Exposure Page

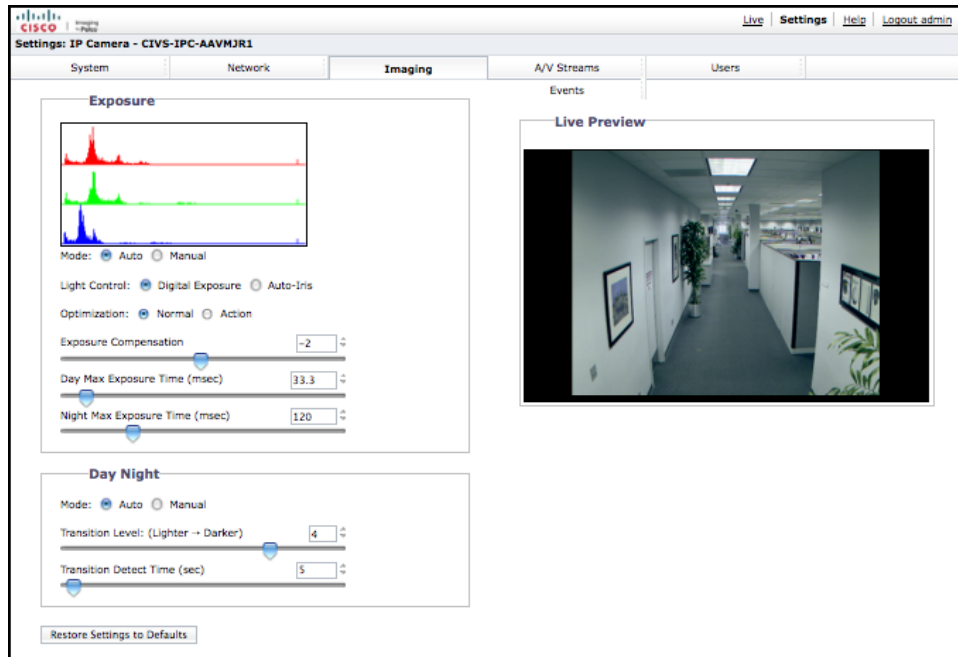

- Step 1** Place your mouse pointer over the Imaging tab.
- Step 2** Select Exposure from the drop-down menu.
- Step 3** Select the Auto mode.
- Step 4** Select the Light Control method: Digital Exposure or Auto-Iris Exposure.
 - **Digital Exposure:** This setting automatically adjusts the sensor exposure time depending on the light level at the scene. For very bright scenes, the exposure time is very short and, as the scene becomes less bright, the exposure time is increased until the maximum exposure time is reached. Digital Exposure is the default setting and provides the best image quality for the majority of scenes.
 - **Auto-Iris Exposure:** This setting automatically adjusts the lens iris depending on the light level at the scene. For this setting, the sensor exposure time is fixed. Select Auto-Iris if the video shows flickering or rolling bands due to 50 Hz or 60 Hz lighting. Most lighting situations do not require this setting.
- Step 5** Select the Exposure Optimization setting: Normal or Action. These are optimizations of the Digital Exposure control.
 - **Normal:** This setting is for very bright scenes and exposure time is very short. As the scene becomes less bright, the exposure time is increased until the maximum exposure time is reached. Normal is the default setting.
 - **Action:** This setting operates similar to Normal except the short exposure times are used for both bright and mid-level lighting. This minimizes the blur in video caused by moving objects. For very low light scenes, Action optimization operates the same as Normal, increasing the exposure time until the maximum exposure time is reached.

- Step 6** Set the Exposure Compensation setting. Move the slider bar to the right to brighten the video, or move it to the left to darken the video. The exposure compensation range is -100 to 100; the default setting is 0 (zero).
- Step 7** Set the Max Exposure Time and Night Max Exposure Time.
- **Max Exposure Time:** This setting controls the maximum time in milliseconds that an image is exposed during daytime conditions. Decreasing Max Exposure Time reduces the blur caused by fast moving objects as the light dims, but it also reduces the light sensitivity of the camera. The exposure range is 1 to 500 msec; the default setting is 33.3 msec.
 - **Night Max Exposure Time:** This setting controls the maximum time in milliseconds that an image is exposed during dim light, such as nighttime conditions. Increase this time to increase the light sensitivity of the camera. The exposure range is 1 to 500 msec; the default setting is 120 msec.
- Step 8** Set the Day Max Exposure Time and Night Exposure Time.
- **Day Max Exposure Time:** This setting controls the maximum time in milliseconds that an image is exposed when the camera is in Day (Color) mode. Decreasing Max Exposure Time reduces the blur caused by fast moving objects as the light dims, but it also reduces the light sensitivity of the camera. The exposure range is 1 to 500 msec; the default setting is 33.3 msec.
 - **Night Max Exposure Time:** This setting controls the maximum time in milliseconds that an image is exposed when the camera is in Night (black-white) mode. Increase this time to increase the light sensitivity of the camera. The exposure range is 1 to 500 msec; the default setting is 120 msec.
- Step 9** Set the Day Exposure Time and the Night Exposure Time.
- **Day Exposure Time:** This setting is the maximum time in milliseconds that an image is exposed during daytime conditions. Decreasing exposure time decreases the light sensitivity of the scene and reduces the blur caused by fast moving objects; however, it increases the amount of noise in the scene. The day maximum exposure time range is 1 to 500 msec; the default setting is 33.3 msec.
 - **Night Exposure Time:** This setting is the maximum time in milliseconds that an image is exposed during nighttime (black-white) conditions. Increase the exposure time to increase light sensitivity of the scene. The night maximum exposure time range is 1 to 500 msec; the default setting is 120 msec.
- Step 10** Set the Day Night mode to Auto or Manual.
- **Auto:** This setting automatically controls the IR cut filter determined by the Transition Level and the Transition Detect settings.
 - **Manual:** This setting sets the IR filter to a fixed position. The filter can be set to the Day (color) position or the Night (black-white) position.
-

Refer to the following section for more information:

- [Day Night Settings, page 3-18](#)

Selecting Manual Exposure Settings

Figure 3-5 Manual Exposure Page

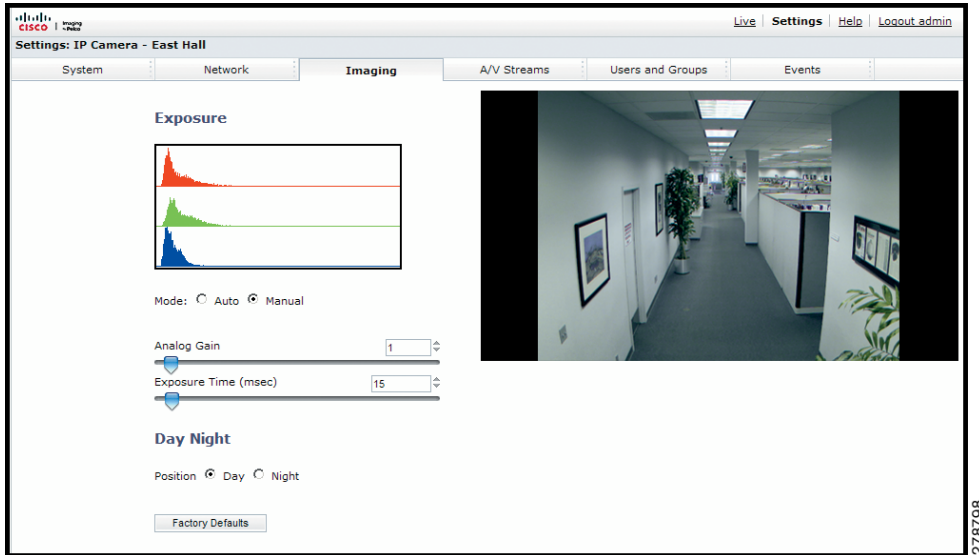

-
- Step 1** Place your mouse pointer over the Imaging tab.
- Step 2** Select Exposure from the drop-down menu.
- Step 3** Select the Manual mode.
- Step 4** Move the Analog Gain slider to the desired position. Increasing the gain increases the brightness of the image, but it also increases the amount of noise in the image. The analog gain range is 1.00 to 15.75; the default setting is 1.00.
- Step 5** Move the Exposure Time slider to the desired position. This setting is the maximum time in milliseconds that the sensor is exposed to the light. Decreasing the maximum exposure time decreases the light sensitivity. The exposure time range is 0.01 to 1000 msec; the default setting is 33 msec.
- Step 6** Set the Day Night Position setting.
- **Day:** Sets the IR filter to the Day (color) position.
 - **Night:** Sets the IR filter to the Night (black-white) position.
-

Refer to the following section for more information:

- [Day Night Settings, page 3-18](#)

Day Night Settings

The Day Night mode controls the position of the IR cut filter, which determines the color or black-white setting of the camera. The Day Night mode settings change depending on the Exposure settings. If the camera is set to Auto Exposure mode, the Day Night mode can be set to Auto or Manual and all of the respective settings are available. If the camera is set to Manual Exposure, the only available Day Night mode setting is Position, which sets the IR filter to either the Day (color) position or the Night (black-white) position.

Day Night Auto and Manual Modes

Day Night Auto Mode

The Day Night Auto mode setting automatically controls the IR cut filter depending on the Transition Level and Transition Detect Time settings.

Transition Level: Determines when the camera changes from day mode (color) to night mode (black-white). Settings include Lighter, Default, and Darker. Set the transition level to Lighter if you want the camera to change modes at a high lux setting. Use Default for normal day/night operation, and use Darker to change modes at a low lux setting.

Table 3-1 Lux Transition Points for Incandescent Lighting

Transition Level Setting	Day to Night Transition Point	Night to Day Transition Point
Darker	1.8 lux	5.7 lux
Default	2.8 lux	5.7 lux
Lighter	4.5 lux	5.7 lux

Transition Detect Time (sec): Controls the length of time the camera is exposed to a light level before it changes to color or black-white mode. This setting is useful for dark scenes where a bright light is momentarily introduced in the scene (for example, when a car with its headlights turned on passes the camera scene).

Day Night Manual Mode

The Day Night Manual mode sets the IR cut filter to a fixed position depending on the Position setting. Available settings include Day and Night.

Day: Sets the IR filter to the Day (color) position.

Night: Sets the IR filter to the Night (black-white) position.



Note

Position is the only available Day Night setting if the camera exposure is set to Manual.

Configuring Auto Focus Settings

Figure 3-6 Auto Focus Page

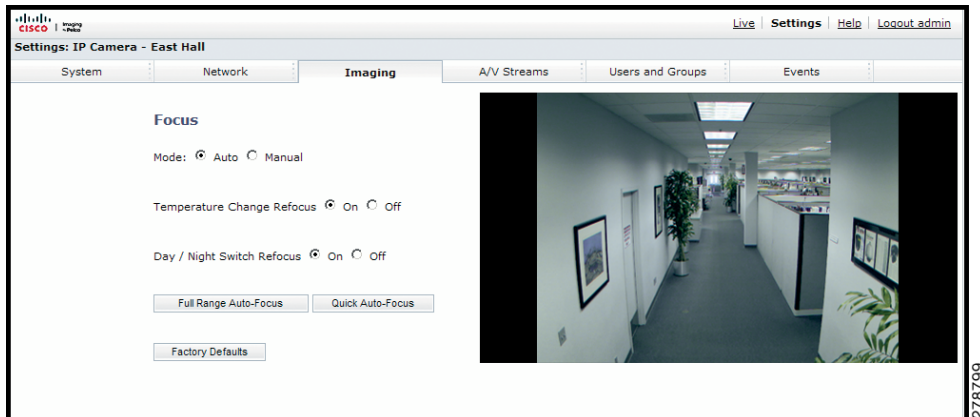

-
- Step 1** Place your mouse pointer over the Imaging tab.
- Step 2** Select Focus from the drop-down menu.
- Step 3** Select the Auto mode.
- Step 4** Set the Temperature Change Refocus setting. The camera is programmed to run a quick automatic focus sequence when the internal temperature sensor of the camera detects an environmental temperature change of 41°F (5°C). This focus sequence adjusts the center focal point of the scene to maintain optimal focus. The default setting is On; select Off to turn off this setting.
- Step 5** Set the Day/Night Switch Refocus setting. The default setting for the Day/Night Switch Refocus is Off. Select On if the camera's focal length is greater than ~25 mm or the night scene uses mostly IR lighting. The best method to determine if the day/night refocus should be enabled is to test the camera with the daytime light conditions, and then test it again with the nighttime light conditions.
- When enabled (On) this setting refocuses the camera when the camera changes from day mode (color) to night mode (black-white) or vice versa. For example, if the camera changes from day mode to night mode, the imager automatically adjusts the back focus for the change in light.
- Step 6** If required, use one of the following buttons to adjust the focus:
- **Full Range Auto-Focus:** The camera starts a full-range search to find the optimal focal point for the scene.
 - **Quick Auto-Focus:** The camera searches for the optimal focal point in a limited range.
 - **Factory Defaults:** The camera resets the auto focus to the factory default setting.
-

Configuring Manual Focus Settings

Figure 3-7 Manual Focus Page

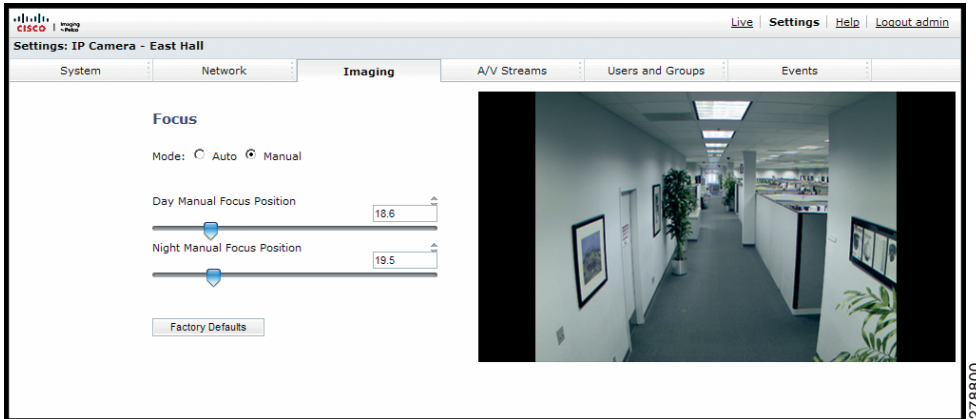

278800

-
- Step 1** Place your mouse pointer over the Imaging tab.
 - Step 2** Select Focus from the drop-down menu.
 - Step 3** Select the Manual mode.
 - Step 4** Set one of the following settings:
 - **Day Manual Focus Position:** This is the position of the focus mechanism when the IR cut filter is applied. The day mode focus position range is 0 to 100.
 - **Night Manual Focus Position:** This is the position of the focus mechanism when the IR cut filter is removed. The night mode focus position range is 0 to 100.
 - **Manual Focus Position:** This is the manual setting of the focus mechanism. The focus range is 0 to 100.
 - Step 5** Set the Manual Focus Position. The focus range is 0 to 100.
 - Step 6** If required, click the Factory Defaults button to reset the focus to the factory default setting.
-

Setting Tone Map Options

Figure 3-8 Tone Map Page

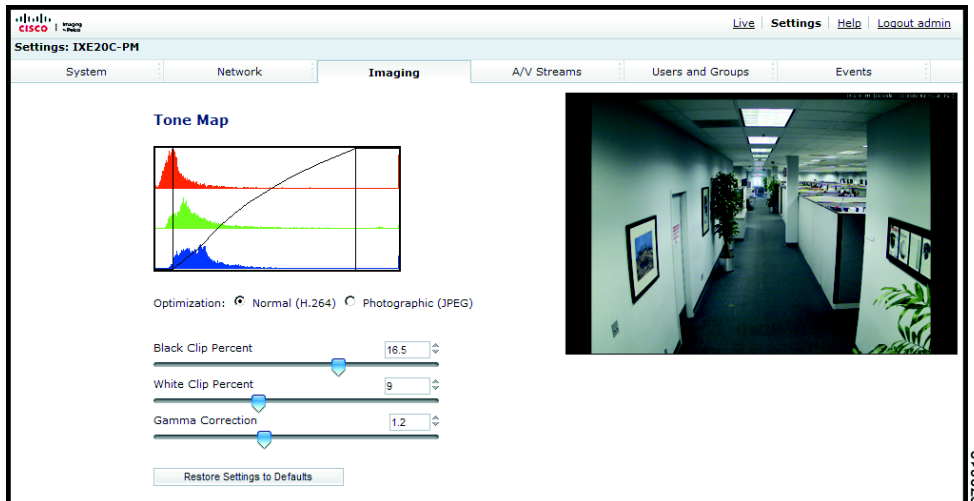

-
- Step 1** Place your mouse pointer over the Imaging tab.
- Step 2** Select Tone Map from the drop-down menu.
- Step 3** Select the Optimization setting:
- **Normal (H.264):** If the compression standard for the primary stream is H.264, set Optimization to Normal (H.264). This is the default setting.
 - **Photographic (JPEG):** If the compression standard for the primary stream is JPEG, set Optimization to Photographic (JPEG).
- Step 4** Move the Tone Map sliders to adjust the following image settings:
- **Black Clip Percent:** Adjusts the percent of pixels set to black. Move the slider to the right to darken the scene by increasing the number of pixels that are mapped to absolute black. The black clip percent range is 0 to 25; the default setting is 0.5.
 - **White Clip Percent:** Adjusts the percent of pixels set to white. Move the slider to the right to lighten the scene by increasing the number of pixels that are mapped to absolute white. The white clip range is 0 to 25; the default setting is 0.5.
 - **Gamma Correction:** Adjusts the details in the light and dark areas of the scene. Move the slider to the left to expose more detail in the light areas of the scene; move the slider to the right to expose more detail in the dark areas of the scene. The gamma corrector range is 0.1 to 3.0; the default setting is 2.2.
- Step 5** If required, click the Factory Defaults button to reset the Tone Map to the factory default setting.
-

Selecting Auto White Balance Settings

Figure 3-9 Auto White Balance Page

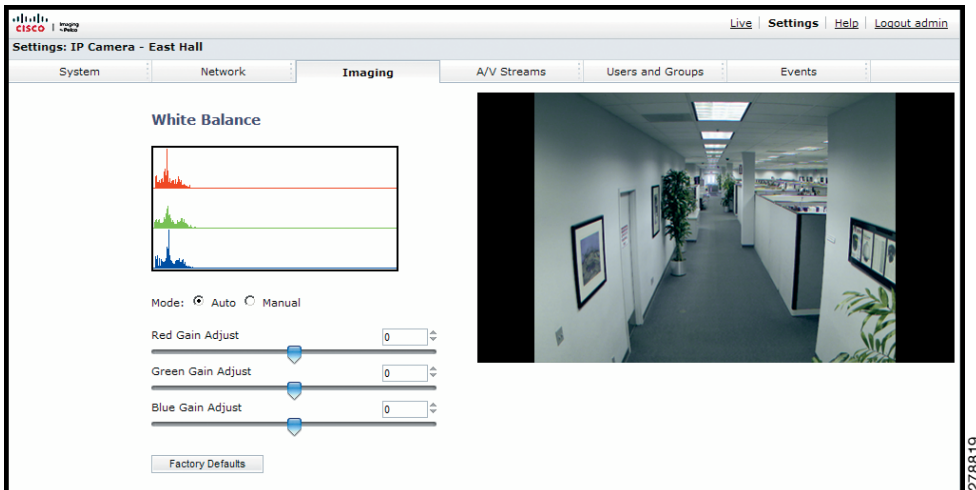

-
- Step 1** Place your mouse pointer over the Imaging tab.
- Step 2** Select White Balance from the drop-down menu.
- Step 3** Select the Auto mode.
- Step 4** Move the sliders to adjust the following settings in Auto mode:
- **Red Gain Adjust:** Adjusts the image output in the red range. Move the slider to the right to increase the red level; move the slider to the left to decrease the red level. As you move the slider, you will see the color change on your monitor. The auto range of adjustment is -1.0 to 1.0 ; the default setting is 0 (zero).
 - **Green Gain Adjust:** Adjusts the image output in the green range. Move the slider to the right to increase the green level; move the slider to the left to decrease the green level. As you move the slider, you will see the color change on your monitor. The auto range of adjustment is -1.0 to 1.0 ; the default setting is 0 (zero).
 - **Blue Gain Adjust:** Adjusts the image output in the blue range. Move the slider to the right to increase the blue level; move the slider to the left to decrease the blue level. As you move the slider, you will see the color change on your monitor. The auto range of adjustment is -1.0 to 1.0 ; the default setting is 0 (zero).
- Step 5** If required, click the Factory Defaults button to reset the white balance to the factory default setting.
-

Selecting Manual White Balance Settings

Figure 3-10 Manual White Balance Page

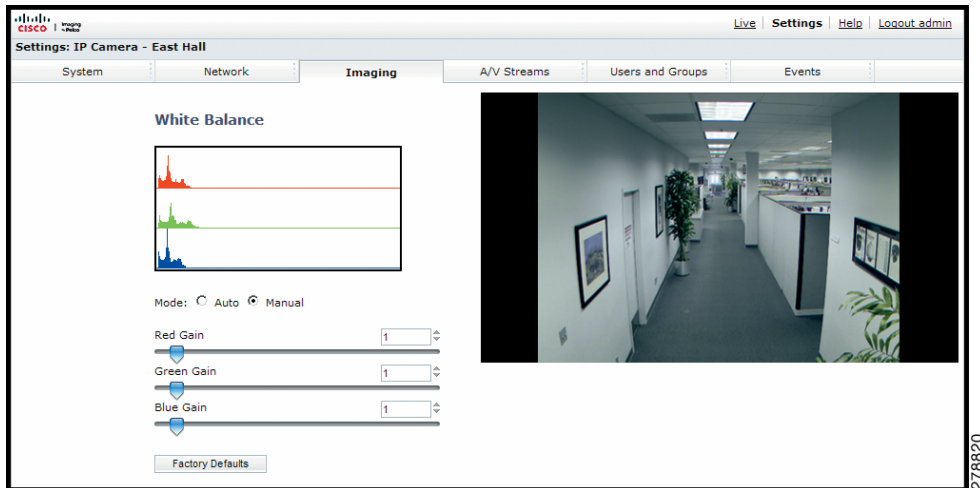

Note

Manual white balance is recommended only for indoor applications that have a single, unchanging primary light source.

- Step 1** Place your mouse pointer over the Imaging tab.
- Step 2** Select White Balance from the drop-down menu.
- Step 3** Select the Manual mode.
- Step 4** Move the sliders to adjust the following settings in Manual mode:
 - **Red Gain:** Adjusts the image output in the red range. Move the slider to the right to increase the red level; move the slider to the left to decrease the red level. As you move the slider, you will see the color change on your monitor. The manual range of adjustment is 0 to 32; the default setting is 1.
 - **Green Gain:** Adjusts the image output in the green range. Move the slider to the right to increase the green level; move the slider to the left to decrease the green level. As you move the slider, you will see the color change on your monitor. The manual range of adjustment is 0 to 32; the default setting is 1.
 - **Blue Gain:** Adjusts the image output in the blue range. Move the slider to the right to increase the blue level; move the slider to the left to decrease the blue level. As you move the slider, you will see the color change on your monitor. The manual range of adjustment is 0 to 32; the default setting is 1.
- Step 5** If required, click the Factory Defaults button to reset the white balance to the factory default setting.

Turning On Window Blanking

Figure 3-11 Window Blanking Page

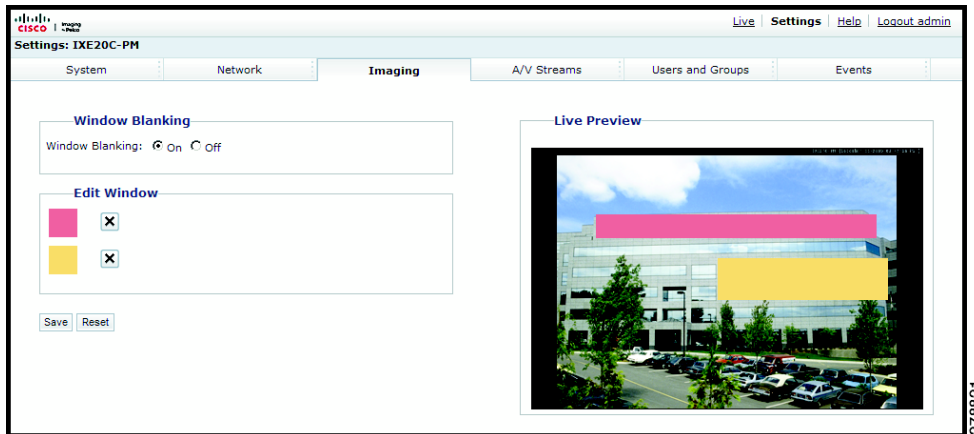

-
- Step 1** Place your mouse pointer over the Imaging tab.
 - Step 2** Select Window Blanking from the drop-down menu.
 - Step 3** Select the On option for Window Blanking.
 - Step 4** Draw a window in the Live Preview area of the page:
 - a. Hold down the left mouse button.
 - b. Drag the mouse diagonally across the area you want to blank.
 - c. A color-coded box appears in the Edit Window section of the page that is the same color as the window drawn in the Live Preview area.



Note Up to four blanked windows can be defined, but the blanked area cannot exceed 50 percent of the field of view.

- Step 5** To resize the window, click and drag one or more of the points until the window is the desired shape and size.
 - Step 6** Click the Save button to save the settings, or click the Reset button to clear all of the information you entered without saving it.
-

Turing Off Window Blanking

-
- Step 1** Place your mouse pointer over the Imaging tab.
 - Step 2** Select Window Blanking from the drop-down menu.
 - Step 3** Select the Off option for Window Blanking.

- Step 4** Click the Save button to save the settings, or click the Reset button to clear all of the information you entered without saving it.
-

Deleting a Window Blanking Area

- Step 1** Place your mouse pointer over the Imaging tab.
- Step 2** Select Window Blanking from the drop-down menu.
- Step 3** In the Edit Window area of the page, click the check box next to the window blanking area you want to delete.
- Step 4** Click the Save button to save the settings, or click the Reset button to clear all of the information you entered without saving it.
-

A/V Streams Tab

Use the A/V Streams tab to configure the video streams for the camera. The A/V Streams tab includes a Video Presets page and a Video Configuration page.

Video Presets

The Video Preset page includes three fully-configured video presets, which include primary and secondary video stream settings for easy setup. These presets may also be used as a starting point for a custom video configuration. These preset configurations vary depending on camera model.

Video Configuration

The Video Configuration page allows you to customize the compression, resolution, image rate, and bit rate of the video streams. The default names for the streams are Primary Stream and Secondary Stream. Although each stream can be configured independently, the settings of one stream can limit the options available to the other stream, depending on the processing power used.

**Note**

Always configure the primary stream before the secondary stream. The primary stream should always be the most resource-intensive of the streams.

**Note**

Improper use of audio/visual recording equipment may subject you to civil and criminal penalties. Applicable laws regarding the use of such capabilities vary between jurisdictions and may require, among other things, express written consent from the recorded subjects. You are solely responsible for insuring strict compliance with such laws and for strict adherence to any/all rights of privacy and personalty.

Refer to the following sections for more information:

- [Selecting a Video Preset Configuration, page 3-26](#)

- [Configuring a Custom Video Stream Configuration, page 3-27](#)
- [Compression Standards, page 3-28](#)
- [Available Camera Resolution, page 3-28](#)
- [Image Rate, page 3-28](#)
- [Bit Rate, page 3-28](#)
- [Quality of Service for Differentiated Services Code Point, page 3-28](#)
- [Rate Control, page 3-29](#)
- [Rate Control, page 3-29](#)
- [Profile, page 3-29](#)

Selecting a Video Preset Configuration

Figure 3-12 Select Video Preset Configuration Page

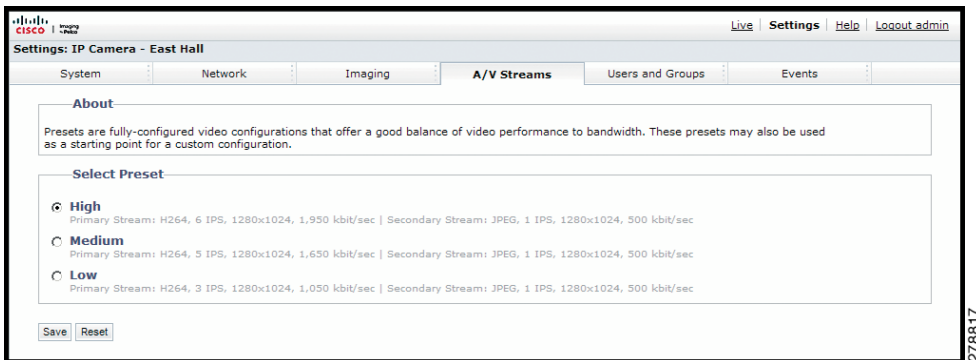

-
- Step 1** Place your mouse pointer over the A/V Streams tab.
 - Step 2** Select the Video Preset option from the drop-down menu.
 - Step 3** Click the button next to the video preset stream configuration (High, Medium, or Low) that you want to select.
 - Step 4** Click the Save button to save the settings, or click the Reset button to clear your selection without saving it.
-

Configuring a Custom Video Stream Configuration

Figure 3-13 Custom Video Stream Configuration Page

The screenshot displays the 'Custom Video Stream Configuration' page. At the top, there are navigation tabs: System, Network, Imaging, A/V Streams (selected), Users and Groups, and Events. Below the tabs, the page title is 'Settings: IP Camera - East Hall'. The main content area is divided into two sections: 'Primary Stream' and 'Secondary Stream'.
Primary Stream: H264, 30 IPS, 1920x1080, 6,400 kbit/sec, CBR, High, IP. Fields include Name (Primary Stream), Compression Standard (H264), Resolution (1920x1080), Image Rate (30 IPS), Bit Rate (6,400 kbit/sec), I-frame Interval (30), QoS (DSCP) Codepoint (34), Rate Control (CBR), Profile (High), and GOP Structure (IP).
Secondary Stream: JPEG, 5 IPS, 1920x1080, 5,500 kbit/sec. Fields include Name (Secondary Stream), Compression Standard (JPEG), Resolution (1920x1080), Image Rate (5 IPS), and Bit Rate (5,500 kbit/sec).
 At the bottom left are 'Save' and 'Reset' buttons. A vertical ID number '278815' is on the right edge.

- Step 1** Place your mouse pointer over the A/V Streams tab.
- Step 2** Select Video Configuration from the drop-down menu.
- Step 3** Click both of the Clear buttons to delete the primary and secondary streams settings.
- Step 4** *Optional:* In the Primary Stream section, type a user-friendly name in the Name box (2 to 64 characters). A user-friendly name makes it easier to recognize the stream (for example, Live and Recording).
- Step 5** Configure the Compression Standard, Resolution, Image Rate, and Bit Rate settings for the primary stream.



Note The compression standard, resolution, image rate, and bit rate settings are dependent on each other. You must first decide the priority setting before you configure a stream. For example, if you want an image rate of 30 ips, set the image rate before you configure the other settings.

- Step 6** Repeat steps 3 through 5 for the Secondary stream.
- Step 7** Click the Save button to save the settings, or click the Reset button to clear all of the information you entered without saving it.

Compression Standards

JPEG: A commonly used video compression scheme, also known as MJPEG. JPEG has the least impact on the camera's processor, but it requires the most bandwidth.

H264: A new version of MPEG-4 compression used in high-definition video players such as Blu-ray™ and HD-DVD. H.264 is the most processor-intensive, but it requires the least amount of bandwidth.

Available Camera Resolution

The resolution capabilities of the cameras are 1080P (1920 x 1080), 720P (1280 x 720), 4CIF (640 x 352), CIF (480 x 272), and QCIF (320 x 176).

Image Rate

The image rate is the number of images per second (ips) available for the video stream configuration. Available image rates are 30, 25, 24, 15, 12.5, 12, 10, 8, 7.5, 6, 5, 4, 3, 2.5, 2, and 1.

**Note**

The maximum image rate setting might not be obtainable due to the programmed compression standard and the resolution of the stream.

Refer to the following section for more information:

- [Chapter 4, “Specifications”](#)

Bit Rate

The bit rate is the quality of the video stream (rendered in kilobits per second). The higher the value, the higher the video quality and bandwidth required.

**Note**

When you change any of the video stream configuration settings, the camera automatically adjusts the bit rate. If you manually reduce the bit rate lower than the camera's automatic setting, the image quality might be reduced and the stream selection options might be limited.

Quality of Service for Differentiated Services Code Point

Quality of Service (QoS) for Differentiated Services Code Point (DSCP) is a code that allows the network to prioritize the transmission of different types of data. This setting is only available with H.264.

NOTES:

- If you are not familiar with DSCP, contact your network administrator before changing this setting.
- Your network must be configured to use QoS. If you are unsure if your network is QoS-aware, contact your network administrator.

Rate Control

The rate control setting determines the bit rate and quality of each frame in the video stream. There might be a trade-off between image quality and the resources required for video storage when selecting a rate control setting.

CBR: The constant bit rate (CBR) streams video at a fixed number of bits per second. CBR uses the full capacity of the bit rate setting for scenes with or without motion. Video is always streamed at the user bit rate setting.

Profile

The profile defines the subset of bit stream features in an H.264 stream, including color reproduction and additional video compression. It is important that the selected profile is compatible with the recording device so that a stream can be decoded and viewed.

Baseline: A simple profile with a low compression ratio. A baseline profile is compatible with more recorders but uses more bits to compress quality video than the other profiles. This profile supports I-frames and P-frames. Use the baseline profile in applications with limited scene changes; for example, an indoor scene with a single, unchanging primary light source and minimal motion.

Main: An intermediate profile with a medium compression ratio. Main is the default profile setting. This profile is compatible with most recorders and uses fewer bits to compress video than the baseline profile; however, it uses more bits than the high profile. The main profile supports I-frames, P-frames, and B-frames.

High: A complex profile with a high compression ratio. This is the primary profile for high-definition television applications; for example this is the profile adopted for Blu-ray and HD-DVD. The high profile supports I-frames, P-frames, and B-frames.

GOP Structure

The group of pictures (GOP) structure is the sequence in which frames are placed within a video stream. The GOP structure always includes intra-coded frames (I-frames) and predictive coded frames (P-frames), but it can also include bi-directionally predictive coded frames (B-frames).

Each GOP structure starts with an I-frame: an image of the complete scene that is used as the reference frame in the structure. P-frames record data changes that are different than the previous frame. This allows the video encoder to save space since the data of the I-frame is not duplicated. B-frames not only capture data changes from the previous frame, but they also capture the data changes from the frame after the B-frame. B-frames are more compressed than P-frames and require more processing power to be decoded.



Note

Do not change the following GOP settings when using the cameras with Cisco Video Surveillance Manager (Cisco VSM). Always use the default settings. The following descriptions are for informational purposes only.

The camera can be configured to use one of the following GOP structures:

- **IP:** A compression that uses only I-frames and P-frames to provide low latency and a high level of decoder support. This GOP structure is compatible with more recorders and decoders than IBBrBP.
- **IBBrBP:** The most sophisticated H.264 compression available. IBBrBP provides the highest quality image at a given bit rate, but it also increases the latency of the video and requires more processing power for decoders.

Advance Sharpening

The Advance Sharpening setting enhances picture detail by sharpening the edges in the picture. When this mode is enabled, there is a trade-off between image quality and the resources required for processing power. The maximum camera resolution and image rate will not be available, but the edges of the image seem sharper. Only use this setting if you cannot achieve the sharpness level you want by adjusting the digital processing settings of the camera. The default setting for Advanced Sharpening is Off.

Users and Groups Tab

Use the Users and Groups tab to create and manage user accounts, group permissions, and to change the way the camera manages the users and groups settings.

Users

User accounts can be created and added to groups to limit the permissions given to individuals logged on to the camera. Use the features on the Users page to create, modify, or delete user accounts.



Note

The only defined user that cannot be deleted is admin; however, the administrator password can be changed. For security purposes, it is important that you change your password after you log on to the device for the first time.

Figure 3-14 User Page

The screenshot shows the 'New User' form in the 'Users and Groups' tab of the Cisco IP Camera web interface. The form includes the following fields and options:

- Username:** A text input field.
- Password:** A text input field.
- Re-type Password:** A text input field.
- First Name:** A text input field.
- Last Name:** A text input field.
- Email:** A text input field.
- Groups:** A list of checkboxes for selecting user groups:
 - Select All
 - Administrators
 - Managers
 - Public (no login required)
 - Operators
 - Viewers

At the bottom of the form, there are buttons for 'New User', 'Delete User', 'Save', and 'Reset'. The 'admin' user is listed in a box on the left side of the form.

Groups

Groups can be created to assign permissions to users within each group. Use the features on the Groups page to create, modify, and delete groups and permissions. Multiple permissions can be assigned to each group.

Figure 3-15 Group Page

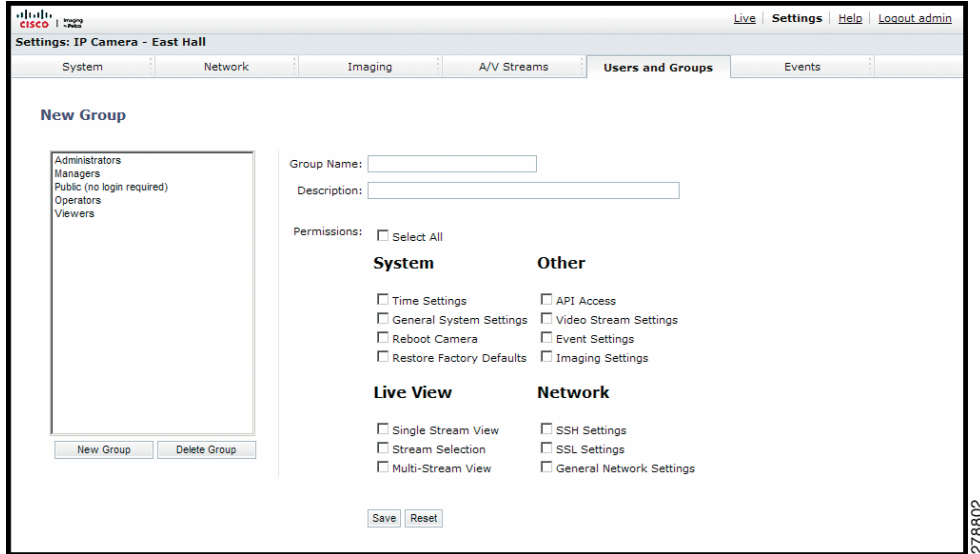

Refer to the following sections for more information.

- [Creating a New User, page 3-31](#)
- [Editing a User, page 3-32](#)
- [Deleting a User, page 3-32](#)
- [Creating a New Group, page 3-33](#)
- [Editing a Group, page 3-33](#)
- [Deleting a Group, page 3-33](#)
- [General Settings for Users and Groups, page 3-34](#)

Creating a New User

- Step 1** Place your mouse pointer over the Users and Groups tab.
- Step 2** Select Users from the drop-down menu.
- Step 3** Click in the Username box and type a user name (2 to 23 alphanumeric characters). User names are not case-sensitive and are saved in lowercase characters.
- Step 4** Click in the Password box and type a password (4 to 16 alphanumeric characters). Passwords are case-sensitive.
- Step 5** Click in the Retype Password box and retype your password.
- Step 6** Click in the First Name box and type the user's first name (1 to 32 alphanumeric characters).
- Step 7** Click in the Last Name box and type the user's last name (1 to 32 alphanumeric characters).
- Step 8** Click in the Email box and type the user's email address.
- Step 9** Select the appropriate check boxes to choose the groups you want to assign to the user. The Users page includes default accounts for the following groups:

- **Select All:** Selects all group definitions.
 - **Administrators:** This is the only defined group that cannot be deleted. This group has access to all permissions.
 - **Managers:** This defined group can be modified or deleted. This group has access to all permissions *except* the restore factory defaults permission.
 - **Public:** This defined group can be modified or deleted. The default permission for this group is single stream view.
 - **Operators:** This defined group can be modified or deleted. The default permissions for this group are single stream view, stream selection, and multistream view.
 - **Viewers:** This defined group can be modified or deleted. The default permissions for this group are single stream view and multistream view.
- Step 10** Click the Save button to save the settings and create a new user. The new user profile appears in the box on the left side of the page. Click the Reset button to clear all of the information you entered without saving it.
-

Editing a User

- Step 1** Place your mouse pointer over the Users and Groups tab.
- Step 2** Select Users from the drop-down menu.
- Step 3** Click the user profile that you want to edit from the box on the left side of the page.
- Step 4** Double-click in each of the text boxes to highlight the text. Type the new information in each text box.



Note The username cannot be modified; this text box is read-only.

- Step 5** Select or clear the appropriate check boxes from the groups list.
- Step 6** Click the Save button to save the settings, or click the Reset button to clear all of the information you entered without saving it.
-

Deleting a User

- Step 1** Place your mouse pointer over the Users and Groups tab.
- Step 2** Select Users from the drop-down menu.
- Step 3** Click the user profile that you want to delete from the defined users section located in the box on the left side of the page.
- Step 4** Click the Delete User button. A dialog box appears with the message “Are you sure you want to delete the user?”
- Step 5** Click OK. The user profile is deleted from the defined user profiles section.



Note The “admin” user cannot be deleted.

Creating a New Group

- Step 1** Place your mouse pointer over the Users and Groups tab.
 - Step 2** Select Groups from the drop-down menu.
 - Step 3** Click in the Group Name box and type a name for the group you are creating (2 to 23 alphanumeric characters).
 - Step 4** Click in the Description box and type a description for the group you are creating (2 to 23 alphanumeric characters).
 - Step 5** Select the appropriate check boxes to choose the permissions you want to assign to this group.
 - Step 6** Click the Save button to save the settings and create a new group; the new group profile appears in the box on the left side of the page. Click the Reset button to clear all of the information you entered without saving it.
-

Editing a Group

- Step 1** Place your mouse pointer over the Users and Groups tab.
 - Step 2** Select Groups from the drop-down menu.
 - Step 3** Click the group profile that you want to edit from the box on the left side of the page.
 - Step 4** Double-click in each of the text boxes to highlight the text. Type the new information in each text box.
 - Step 5** Select or clear the appropriate check boxes from the groups list.
 - Step 6** Click the Save button to save the settings, or click the Reset button to clear all of the information you entered without saving it.
-

Deleting a Group

- Step 1** Place your mouse pointer over the Users and Groups tab.
- Step 2** Select Groups from the drop-down menu.
- Step 3** Click the group profile that you want to delete from the defined group section located in the box on the left side of the page.
- Step 4** Click the Delete Group button. A dialog box appears with the message “Are you sure you want to delete the group?”
- Step 5** Click OK. The group profile is deleted from the defined group profile section.

NOTES:

- If a user has only one group assigned and that group is deleted, the user will lose all permissions. An administrator will have to assign a new group to that user to establish permissions.
- The Administrators and Public groups cannot be deleted.

General Settings for Users and Groups

The general settings for user and groups allow you to change the way the camera manages the users and groups settings. These settings can be managed on a camera-to-camera basis or by using a centralized server to apply changes to multiple cameras.

Figure 3-16 User and Group Settings Page

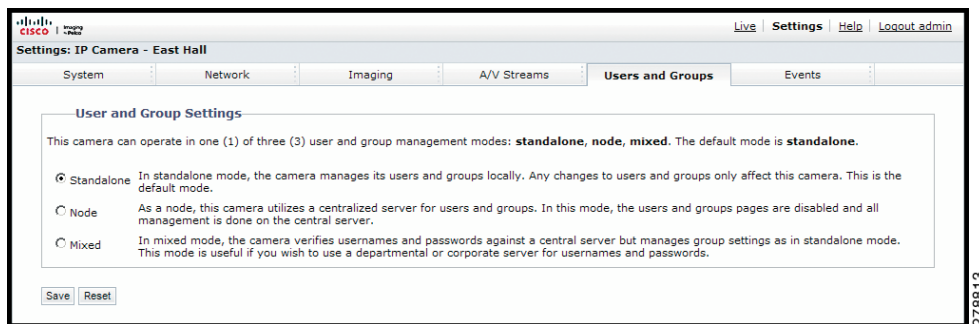

The available general settings for users and groups are as follows:

- **Standalone:** The camera manages its users and groups locally. Any changes to users and groups affect only the camera that you are accessing. Standalone is the default setting.
- **Node:** The camera uses a centralized server for users and groups. In this mode, the users and groups pages are disabled and all management is done on the central server. Any changes to users and groups affect all cameras connected to the central server.
- **Mixed:** The camera verifies user names and passwords against a central server but manages the group settings locally. This is useful if you want to use a departmental or corporate server for user names and passwords. In this mode, the settings on the users page are limited, and any changes to user names and passwords are done on the LDAP server. While changes to user names and passwords affect all cameras connected to the LDAP server, group permissions must be managed from each camera individually.

**Note**

The Node and Mixed settings are advanced controls. Consult your network administrator to obtain the required information.

Setting the Camera to Node

- Step 1** Place your mouse pointer over the Users and Groups tab.
- Step 2** Select General Settings from the drop-down menu.

- Step 3** Click the Node option button. The Server box appears.
 - Step 4** Click in the Server box, and then type the name of the central server.
 - Step 5** Click the Save button to save the settings, or click the Reset button to clear all of the information you entered without saving it.
-

Setting the Camera to Mixed

- Step 1** Place your mouse pointer over the Users and Groups tab.
 - Step 2** Select General Settings from the drop-down menu.
 - Step 3** Click the Mixed option button. The LDAP Server and Base DN boxes appear.
 - Step 4** Click in the LDAP Server and Base DN boxes, and type the necessary information in each box.
 - Step 5** Click the Save button to save the settings, or click the Reset button to clear all of the information you entered without saving it.
-

Events Tab

Use the Events tab to program camera events.

Events are activated by programmed event sources that tell the device how to react when an event occurs. Event handlers are the actions that the device takes when an event occurs. For example, a system source can be programmed to send email to an operator if the system shuts-down and restarts.

Sources

The camera supports one physical input alarm source, a system source, and a timer source. The Alarm source is the camera input for an external signaling device, such as a door contact or motion detector. The System source is activated when the camera restarts. The Timer source is a user-defined event that activates an event after a specified amount of time. For example, the timer can be activated every 60 seconds to save an image to an SD card.

Handlers

The device supports a Send Email handler, a “Write JPEG to SD Card handler,” and an “Upload JPEG to FTP Server handlers.” The Send Email handler sends an email to a defined email address when an event is activated. The “Write JPEG to SD Card” saves a JPEG of the activated event to an SD card. The “Upload JPEG to FTP Server” saves a JPEG of the activated event to a defined FTP server.

Sources

Figure 3-17 New Event Source Page

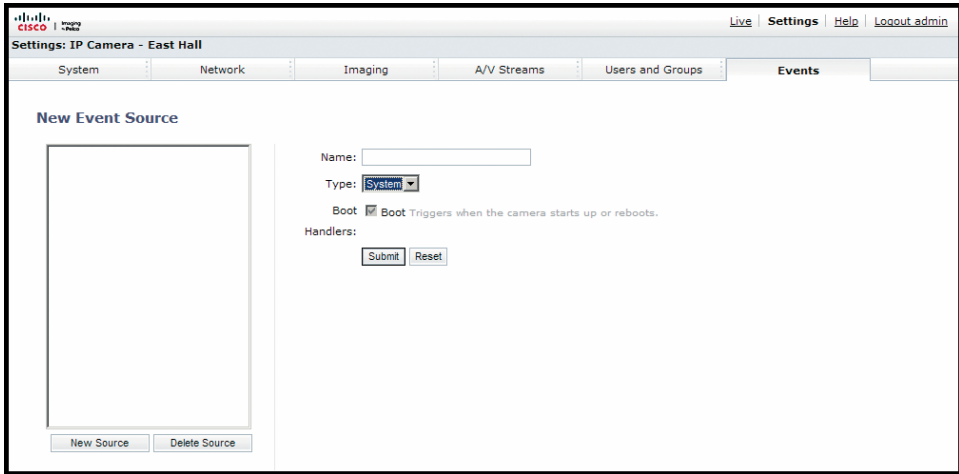

An event is a preprogrammed camera function that is automatically activated by an event source. The camera supports the following types of event sources:

- **Alarm Source:** The camera supports one alarm source. The sources are the camera inputs for external signaling devices, such as door contacts or motion detectors.
- **System Source:** A system source is activated when the camera restarts.
- **Timer Source:** A timer source is a user-defined event. The user can program the timer to activate an event after a specified amount of time. For example, the timer can be activated every 60 seconds to save an image to an SD card.

Creating an Alarm Event Source

-
- Step 1** Place your mouse pointer over the Events tab.
 - Step 2** Select Sources from the drop-down menu.
 - Step 3** Click in the Name box and type a user-friendly name (2 to 23 alphanumeric characters).
 - Step 4** Select Alarm from the Type drop-down menu.
 - Step 5** Move the Dwell Time slider to set the amount of time in seconds that the alarm is active. The dwell time range is 0.1 to 200 seconds; the default setting is 0.1.
 - Step 6** Select either normal or reversed from the Polarity drop-down menu.
 - Step 7** Select either true or false from the Supervised drop-down menu.
 - Step 8** Click the Submit button to save the settings, or click the Reset button to clear all of the information you entered without saving it.
-

Creating a System Event Source

- Step 1** Place your mouse pointer over the Events tab.
 - Step 2** Select Sources from the drop-down menu.
 - Step 3** Click in the Name box and type a user-friendly name (2 to 23 alphanumeric characters).
 - Step 4** Select System from the Type drop-down menu.
 - Step 5** Select the Boot check box to activate an event when the camera reboots.
 - Step 6** Click the Submit button to save the settings, or click the Reset button to clear all of the information you entered without saving it.
-

Creating a Timer Event Source

- Step 1** Place you mouse over the Events tab.
 - Step 2** Select Sources from the drop-down menu.
 - Step 3** Click in the Name box and type a user-friendly name (2 to 23 alphanumeric characters).
 - Step 4** Select Timer from the Type drop-down menu.
 - Step 5** Click in the Frequency box and type a number. Select seconds, minutes, hours, or days from the Frequency drop-down menu.
 - Step 6** Click the Submit button to save the settings, or click the Reset button to clear all of the information you entered without saving it.
-

Editing an Event Source

- Step 1** Place your mouse pointer over the Events tab.
 - Step 2** Select Sources from the drop-down menu.
 - Step 3** Click the source profile that you want to delete from the defined source box located on the left side of the page.
 - Step 4** Make any necessary changes to the available fields.
 - Step 5** Click the Submit button to save the settings, or click the Reset button to clear all of the information you entered without saving it.
-

Deleting an Event Source

- Step 1** Place your mouse pointer over the Events tab.
- Step 2** Select Sources from the drop-down menu.
- Step 3** Click the source profile that you want to delete from the defined source box located on the left side of the page.

- Step 4** Click the Delete Source button. A dialog box appears with the message “Are you sure you want to delete the source?”
- Step 5** Click OK. The source profile is deleted from the defined source box.

Handlers

Figure 3-18 New Event Handler Page

Event handlers are the actions that the camera takes when an event occurs. The camera supports the following event handlers:

- **Send Email:** Sends an email to a defined email address when an event is activated. The Simple Mail Transfer Protocol (SMTP) server must be configured to accept the camera’s IP address.
- **Write JPEG to SD Card:** Saves a JPEG of the activated event to an SD card. An SD card must be installed in the device for this handler to function.



Note The SD card must be formatted as FAT32. Other formats are not compatible with the camera.

- **Upload JPEG to FTP Server:** Saves a JPEG of the activated event to a defined FTP server.

Creating an Event Handler: Send Email



Note To use email notification, the camera must be connected to a local area network (LAN) that maintains an SMTP mail server. Consult your network administrator for information on configuring email notification on your local network.

- Step 1** Configure the SMTP server to send email.

- Step 2** Place your mouse pointer over the Events tab.
- Step 3** Select Handler from the drop-down menu.
- Step 4** Click in the Name box and type a user-friendly name (2 to 23 alphanumeric characters).
- Step 5** Select Send Email from the Type drop-down menu.
- Step 6** Click in the text boxes (To, From, Subject, and Message), and then type the necessary information in each text box.
- Step 7** Select the JPEG Snapshot box if you want to send a JPEG as an attachment.
- Step 8** Select the Attach Raw Event Data box if you want the email to include extra data about the event. For example, select this box if the event is triggered by an alarm and you want to receive data about the state, time, or type of alarm.
- Step 9** If you do not want the handler activated every time an event occurs, set filters for the handler.
- Select the day(s) of the week on which you want emails to be sent.
 - Type times in the Start and End boxes for the days you have selected. Use time values in 24-hour notation (for example, use 0800 for 8:00 a.m., 1600 for 4:00 p.m.).
- Step 10** Select one or more event sources to send an email when those event sources are activated.
- Step 11** Click the Submit button to save the settings, or click the Reset button to clear all of the information you entered without saving it.
-

Refer to the following sections for more information:

- [System Tab, page 3-7](#)
- [Example Handler Filter Setup, page 3-42](#)

Creating an Event Handler: Write JPEG to SD Card

- Step 1** Install an SD card in the SD card slot located on the back of the camera.



Note The SD card must be formatted as FAT32. Other formats are not compatible with the camera.

- Step 2** Place your mouse pointer over the Events tab.
- Step 3** Select Handlers from the drop-down menu.
- Step 4** Click in the Name box and type a user-friendly name (2 to 23 alphanumeric characters).
- Step 5** Select “Write JPEG to SD Card” in the Type drop-down menu.
- Step 6** The JPEG files saved to the SD card will be given file names that correspond to the date and time of the event. Select a time standard from the “File name” drop-down menu.
- Step 7** Click in the Size limit box and type a number. Select Kilobytes, Megabytes, or Gigabytes from the Size Limit drop-down menu.



Note Do not select a size limit that is larger than the amount of memory on the SD card. For example, if the SD card is 2 MB, do not exceed 2 MB in the Size Limit box.

- Step 8** If you do not want the handler activated every time an event occurs, set filters for the handler.
- Select the day(s) of the week on which you want JPEGs saved to the SD card.
 - Type times in the Start and End boxes for the days you have selected. Use time values in 24-hour notation (for example, use 0800 for 8:00 a.m., 1600 for 4:00 p.m.).
- Step 9** Select one or more sources to save a JPEG to the SD card when those event sources are activated.
- Step 10** Click the Submit button to save the settings, or click the Reset button to clear all of the information you entered without saving it.
-

Refer to the following sections for more information:

- [Example Handler Filter Setup, page 3-42](#)

Creating an Event Handler: Upload JPEG to FTP Server

- Step 1** Place your mouse pointer over the Events tab.
- Step 2** Select Handlers from the drop-down menu.
- Step 3** Click in the Name box and type a user-friendly name (2 to 23 alphanumeric characters).
- Step 4** Select “Upload JPEG to FTP Server” in the Type drop-down menu.
- Step 5** Click in the Server box and type the server address (1 to 32 alphanumeric characters).
- Step 6** Click in the Username box and type the user’s name (1 to 32 alphanumeric characters).
- Step 7** Click in the Password box and type a password (4 to 16 alphanumeric characters).
- Step 8** Click in the Base Path box and type the base path (1 to 32 alphanumeric characters).
- Step 9** The JPEG files uploaded to the FTP server will be given file names that correspond to the date and time of the event. Select a time standard from the “File name” drop-down menu.
- Step 10** If you do not want the handler activated every time an event occurs, set filters for the handler.
- Select the day(s) of the week on which you want JPEGs saved to the FTP server.
 - Type times in the Start and End boxes for the days you have selected. Use time values in 24-hour notation (for example, use 0800 for 8:00 a.m., 1600 for 4:00 p.m.).
- Step 11** Select one or more sources to save a JPEG to the FTP server when those event sources are activated.
- Step 12** Click the Submit button to save the settings, or click the Reset button to clear all of the information you entered without saving it.
-

Refer to the following sections for more information:

- [Example Handler Filter Setup, page 3-42](#)

Creating an Event Handler: Open/Close Relay

- Step 1** Place your mouse pointer over the Events tab.
- Step 2** Select Handlers from the drop-down menu.
- Step 3** Click in the Name box and type a user-friendly name (2 to 23 alphanumeric characters).

-
- Step 4** Select Open/Close Relay in the Type drop-down menu.
- Step 5** Move the On Time slider to set the amount of time that the relay will remain open. The time range is 0.1 to 200 seconds; the default setting is 0.1.
- Step 6** Move the Off Time slider to set the amount of time that the relay will remain closed. The time range is 0.1 to 200 seconds; the default setting is 0.1.
- Step 7** Click in the Pulse Count box and type a number.
- Step 8** If you do not want the handler activated every time an event occurs, set filters for the handler.
- Select the day(s) of the week on which you want the relay opened/closed.
 - Type times in the Start and End boxes for the days you have selected. Use time values in 24-hour notation (for example, use 0800 for 8:00 a.m., 1600 for 4:00 p.m.).
- Step 9** Select one or more event sources to open/close the relay when those event sources are activated.
- Step 10** Click the Submit button to save the settings, or click the Reset button to clear all of the information you entered without saving it.
-

Refer to the following sections for more information:

- [Example Handler Filter Setup, page 3-42](#)

Editing an Event Handler

-
- Step 1** Place your mouse pointer over the Events tab.
- Step 2** Select Handlers from the drop-down menu.
- Step 3** Click the handler profile that you want to delete from the defined handler box located on the left side of the page.
- Step 4** Make any necessary changes to the available fields.
- Step 5** Click the Submit button to save the settings, or click the Reset button to clear all of the information you entered without saving it.
-

Deleting an Event Handler

-
- Step 1** Place your mouse pointer over the Events tab.
- Step 2** Select Handlers from the drop-down menu.
- Step 3** Click the handler profile that you want to delete from the defined handler box located on the left side of the page.
- Step 4** Click the Delete Handler button. A dialog box appears with the message “Are you sure you want to delete the handler?”
- Step 5** Click OK. The handler profile is deleted from the defined handler box.
-

Example Handler Filter Setup

If you do not want a handler activated every time an event occurs, use the filter fields to limit handlers. For example, you only want a handler activated when an event occurs after business hours. Your business is open Monday through Saturday, 8:00 a.m. to 6:00 p.m., and it is closed on Sunday.

-
- Step 1** Create a handler for Monday through Saturday:
- Select the day filter fields Monday through Saturday.
 - Type **0000** in the Start box and **0800** in the End box.
 - Click the plus (+) button to add another time range. Type **1800** in the second Start box and type **2400** in the second End box.
 - Select the source(s) that activates the handler.
 - Click the Submit button to save the handler.
- Step 2** Create a second handler for Sunday:
- Select Sunday from the day filter fields.
 - Do not set a Start time or End time as this is a 24-hour event.
 - Select the source(s) that activates the handler.
 - Click the Submit button to save the second handler.
-

Help Menu

Online Help documents the basic instructions for configuring the camera. Click the Help hyperlink in the navigation bar to access these instructions.

Log Off Menu

To log off, click the Log Off button in the navigation bar. A login dialog box appears.



CHAPTER 4

Specifications

- [General](#)
- [Mechanical](#)
- [Environmental](#)
- [Physical](#)
- [Video](#)

General	
Imaging Device	1/3-inch (effective)
Imager Type	CMOS
Imager Readout	Progressive scan
Maximum Resolution	1920 x 1080
Signal-to-Noise Ratio	50 dB
Auto Iris Lens Type	DC drive
Electronic Shutter Range	1~1/100,000 sec
Wide Dynamic Range	60 dB
White Balance Range	2,000 to 10,000K
Sensitivity	f/1.2; 2850K; SNR >24 dB Color (1x/33 ms)0.5 lux Color SENS (15x/500 ms)0.12 lux Mono (1x/33 ms)0.25 lux Mono SENS (15x/500 ms)0.03 lux
Dome Attenuation	ClearZero light loss Smokedf/1.0 light loss
Construction	Back boxCast aluminum Trim ringPolycarbonate plastic BubbleAcrylic plastic
Finish	White
Available Languages	English

Supported Protocols	TCP/IP, UDP/IP (Unicast), UPnP, DNS, DHCP, RTP, RTSP, NTP, IPv4, SNMP, QoS, HTTP, SMTP, FTP
Users	Up to 20 simultaneous users, depending on resolution settings (2 guaranteed streams)
Security Access	Password-protected
Certifications/Ratings/Patents	CE, Class B FCC, Class B UL/cUL listed C-Tick
Electrical	
Port	RJ-45 connector for 100BASE-TX Auto MDI/MDI-X
Cable Type	Cat-5 or better for 100BASE-TX
Power Input	24 VAC or PoE (IEEE 802.3af class 3)
Power Consumption	< 6W
Current Consumption	PoE < 200 mA maximum 24 VAC < 295 mA nominal; < 390 mA maximum
Local Storage	Micro SD
Alarm Input	10 VDC maximum, 5 mA maximum
Alarm Output	0 to 15 VDC maximum, 75 mA maximum
Service Port	External 3-connector, 2.5-mm provides NTSC/PAL video output
Accessory Port	Connects accessories
Mechanical	
Lens Mount	CS-mount, adjustable
Pan/ Tilt Adjustment	Pan368_ Tilt160 (10 to 170) Rotate355
Environmental	
Operational Temperature	32 to 122°F (0 to 50°C)
Operational Humidity	20% to 80%, noncondensing
Physical	
Dimensions (DxWxH)	5.4 x 3.1 x 3.0 in. (13.7 x 7.9 x 7.6 cm)
Weight (without lens)	Unit 2.0 lb (0.9 kg) Shipping 6.0 lb (2.7 kg)
Video	
Video Encoding	H.264 base profile and MJPEG
Video Streams	Up to 2 simultaneous streams; the second stream is variable based on the setup of the primary stream

Supported Frame Rates	30, 15, 10, 5, 1
Video Encoding	H.264 base profile and MJPEG
Video Streams	Up to 2 simultaneous streams; the second stream is variable based on the setup of the primary stream
Supported Resolutions	1080P (1920 x 1080), 720P (1280 x 720), 4CIF (640 x 352), CIF (480 x 272), and QCIF (320 x 176)

